

Alfalfa House Members Council Meeting - minutes

Date: 22 August 2017

Time: 7pm

Location: Meeting Space, 8-10 Brown Street, Newtown

Facilitator: Katherine Lustig, Chair

Minutes: Renata Field

Timekeeper: David Winterton

Meeting opened at: 7:05pm

Acknowledgement of Country: Before we begin the meeting, I would like to acknowledge and pay respect to the traditional owners, both past and present, of the land we occupy and upon which we meet — the Gadigal people of the Eora Nation. It is also upon their ancestral lands that Alfalfa House is built.

1. Attendance and Apologies

Attendance: Katherine Lustig (MC), Jonny Green (MC), Matt McMillan (MC), David Winterton (MC), Maurice Cabrera (Manager), Vanessa Cullen, Ollie Fity, Ran de Silva (staff), Yue Ajioka (staff), Stevie Bee, Jenny Millman, Emma Lees, Bruce Deikman, Renata Field (MC), Victoria Taylor (MC), Catherine O'Keefe (MC), Ian Barralet, Paul Boundy, Sarah McMillan (arrived 7:30pm)

Apologies: Lucy Williams Moore, Julia Gove

2. Approval of Agenda

That the agenda be approved.

Moved: Catherine; Seconded: Victoria

3. Consent Agenda

3.1. Adoption of Previous Minutes

That the minutes of the July 2017 meeting be adopted.

3.2. New Members and Cancellations

That members with the following membership numbers: 12373 to 12458 with 5 skipped/blank records (12382, 12393, 12394, 12420, 12455) be accepted as new members.

That members with the following membership numbers be cancelled: 1350, 2285, 2605, 3353, 4010, 4172, 4375, 4558, 4613, 4962, 5073, 5211, 5473, 5518, 5664, 5727, 5918, 6136, 6269, 6330, 6984, 7184, 7187, 7249, 7367, 7564, 7596, 7768, 7793, 7855, 7867, 7868, 7870, 8052, 8223, 8268, 8509, 8551, 8564, 8619, 8706, 8708, 8744, 8757, 8841, 8849, 8899, 8903, 8907, 8920, 8942, 9032, 9076, 9310, 9373, 9467, 9477, 9479, 9611, 9669, 9671, 9742, 9815, 9913, 9967, 10005, 10027, 10039, 10097, 10126, 10148, 10149, 10154, 10230, 10237, 10269, 10367, 10368, 10404, 10435, 10479, 10527, 10531, 10628, 10638, 10670, 10671, 10687, 10708, 10715, 10721, 10732, 10736, 10757, 10761, 10766,

10768, 10770, 10773, 10785, 10798, 10800, 10802, 10803, 10806, 10807, 10808, 10811, 10814, 10822, 10823, 10828, 10830, 10840, 10844, 10846, 10848, 10849, 10852, 10864.

3.3. Out-of-session Decisions/Proposals

3.3.1 That AH keeps completed paper membership application forms for 12 months from the time a digital record has been made; and thereafter the completed paper membership application forms may be destroyed.

[Victoria - subject to the questions in my email 15.8.17]

3.3.2 That proposals, reports and other information for the agenda must be submitted at least one week prior to the relevant MC meeting.

3.4. Reports from Working Groups

3.4.1. Governance

3.4.1.1 Annual Subscription Fee detail - quarterly fees (Bruce, Stevie and Victoria)

Proposal: That ASF quarterly fees be adopted, and implement as below from Wednesday 23 August 2017

1. All members of Alfalfa House are subject to the Annual Subscription Fee (ASF) of \$20 (including GST), payable from 1 January each year. Members have until 31 January to pay the ASF. This means that during January each year, a member benefits from the 10% discount whether or not they pay the ASF. From 1 February each year, if the member has not paid their ASF, they will not benefit from the 10% discount.

2. New members pay their initial Annual Subscription Fee on the day they join; the amount payable to be calculated at quarterly rates, depending in which quarter of the calendar year they join and as outlined:

If joining from:

- 1 January to 31 March, the initial Annual Subscription Fee for new members will be \$20 (including GST);
- 1 April to 30 June, the initial Annual Subscription Fee for new members will be \$15 (including GST);
- 1 July to 30 September, the initial Annual Subscription Fee for new members will be \$10 (including GST);
- 1 October to 31 December, the initial Annual Subscription Fee for new members will be \$5 (including GST).

From 1 January the following year, new members will be subject to clause 1.

3. No new Alfalfa House memberships can be approved after the last MC meeting of the calendar year. As such, from 15 December each year, new members will be permitted to pay the full fee of \$20 (including GST) and their membership will be extended to end of the following calendar year.

4. If a member chooses not to pay their Annual Subscription Fee, they remain a member of Alfalfa House, but do not receive the 10% discount.

5. Previous decisions about the procedure for ASF (on the volunteer shift in lieu, GST, and unused volunteer discounts) still apply.

3.4.1.2 Alfalfa House - governance working group meeting

The governance working group is open to members who are interested in contributing to governance, compliance and legal processes for Alfalfa House, and is now being convened by Victoria Taylor. The governance working group for Alfalfa House will meet on Saturday, 2 September 2017 10.30am, upstairs at Lentil as Anything, 391 King Street.

We will -

- review the previous failure to update the Rules; and
- prepare to update the Rules.

3.4.2. Premises Solutions, Shop Development and Affordability

NIL

3.4.3. Sustainability

NIL

3.4.4. Volunteer Engagement

NIL

3.4.5. Community Outreach

NIL

3.4.6. Staff Liaison

Consulted with staff, MC and manager regarding upcoming 6 monthly review of Manager.

3.4.7. Marketing

NIL

3.4.8. Website

See main body of agenda.

3.4.9. Finance

July 2017 Treasurer's Report

https://drive.google.com/open?id=1_YtASQofpPL6-63K1K6r-aISXy2yJO-IXuTq0wGeYYc

July 2017 Dashboard

<https://drive.google.com/open?id=0B2CzrZkqx6HpQXZJOGxyZmZPLXM>

3.5. Manager's Report

[Manager's report](#)

3.6. Staffing (appointments and resignations)

That AH accept the appointment of Tallulah Ebbs effective from 31 July 2017.

3.7. Deferred Matters / Business Arising

Item	When expected	Status
Catherine: Provide contact details to Maurice for Bass Floors		Closed
Maurice: Confirm with FTD if there will be shelf space for groceries to be put at the till to make checkout easier.		Open
Maurice: Ensure that freezer running costs are included in the costed proposal.		Open
Marketing Working Group: Present alternative sign wording to MC for approval.		Closed
Victoria: Investigate specific case of member organisation which has a single membership number used by multiple staff for shopping.		On-going
Community Outreach Working Group: Review opportunity to bring in an organisational membership / subscription fee for corporates and not-for-profits, and bring a proposal back to MC.		Open

3.8. Food Grants

nil

3.9. Workplace Health and Safety

nil

That the Consent Agenda Items be approved.

Moved: Catherine; seconded: Jonny

4. Website Working Group (Jenny, 10 mins)

[Website WG report](#)

The Website Working Group has been In charge of implementing the veggie box pilot scheme. It is currently in week 5 of the 6 week pilot. Jenny improved the technology for online payment. Around 7 veggie boxes delivered each Wednesday. Feedback has been received from 4 people on the pilot and improvements implemented during the pilot including

providing a list of what is in the box, what's not in the box and a recipe. Allows buyers to plan meals. No breakage, good quality. They have received feedback on the type of boxes. \$6 is charged to members for delivery. We pay \$42 for delivery, delivery costs \$40, so need at least 7 boxes to be viable. No additional staffing costs are associated.

There is a higher cost for delivery outside the 5km radius.

The number of boxes has to be limited as driver can only deliver a certain number of boxes at \$80 for 2 hours. Jenny can put a limit on the number of orders.

Katherine asked how the trial has affected sales to the members involved in the trial.

Maurice said a survey would be run at the end with the pilot. Katherine asked if it was possible for real data on the participating members to be obtained.

Katherine also noted that she has not been getting the extra discount price on anything delivered during this trial.

Jenny said she is sorting out discounts.

5. Shop Strategy (Maurice, Lucy & Julia, 40 mins)

Please find below the Shop strategy which outlines the overall plan on how the shop is managed with regards to implementing the organisation goals including the key areas of Produce, Groceries and Volunteering.

[Alfalfa House Shop Strategy](#)

Maurice gave an overview of the Strategy, including the note that we are more than a retail shop but a community organisation for people to contribute and give back, educate each other. Stopped doing community development and workshops, now moving forward and reconnecting.

It was asked that the volunteering strategy be added to the overall strategy with assistance from Julia / Volunteer WG.

Catherine commented that it is a good summary strategy and asked if there would be detail, numbers, and actions. For example, detailing strategically what should be stocked? Or was it still at the overall detail.

Maurice said that it is still at an overview level, including because the Groceries Coordinator has only been in the position less than 3 months. Detail and an underpinning plan may take 3-6 months.

Catherine suggested not deleting any shop items until comprehensively looked at.

Maurice said that overall strategies were being made, no items being deleted at present.

Catherine asked for the floorspace (m²) that returns revenue, and Maurice was not sure.

Renata asked that groceries objectives be added including

- supporting food produced by cooperatives
- minimal packaging
- supporting indigenous foods where possible

Catherine also suggested supporting micro business where possible.

Stevie talked about minimising packaging and asked about including strategy for working with suppliers to minimise waste and supply in bulk.

Maurice advised this is happening already in a number of areas such as bulk vegan cheese.

Katherine said the Strategy needed to show how sales will be driven in the future, including with financial projections.

Maurice said it would be great to have action points for how working groups can work on targets such as social media, or the finance working group. He advised he is tracking spending, which is up in the last 2 weeks. More looking into detail will be needed before we can come up with a figure such as increasing sales by 10%.

Stevie's view was that the next stage is required first and that the Strategy was not complete enough to adopt, still needing the "nuts and bolts, flesh on the bones".

Catherine said it was a big achievement to have developed this so far but that more layers were needed.

David gave the example that 'staples' is a broad term that should be defined.

Katherine mentioned strategies for loss leading and suggested these could be defined by our top sellers.

Matt queried if "staple" referred to things used in the kitchen or to the most commonly bought items.

Maurice said that they needed to present the figures on top selling items, volume of items sold, and collect data. Once they have that, they can meet and report on what we currently loss lead on. Maurice advised he can collate this data.

Action item: Maurice will work with Catherine and Finance Working Group to add details.

VWG will add the detail to the volunteer engagement strategy.

Bring back to the next MC meeting

Proposal: That approval is given to adopt the Shop Strategy for the 2017/18 financial year. Not carried; action items pending.

6. Shop Development (Maurice, 40 mins)

This proposal provides an in depth look at known historical issues with regards to our shop design, product placement and functionality issues. The basis for this redesign proposal is to address each of these issues, utilising commissioned WHS worksite assessment and historical financial data with regards to our declining sales revenues. We engaged a professional service provider Forward Thinking Design, all work is provided on a pro-bono basis, to present a final plan of the shop redesign. Please see below documents for more detail.

[Shop Redesign proposal](#) (Maurice)

Design layout and Quotes:

[FTD Design proposal](#) (Vanessa Cullen)

[Maker Space quote for FTD proposal](#) (Oliver Fity)

[Fit Out Crew quote for FTD proposal](#) (2nd quote)

[Quote to replace vinyl flooring](#) (Signature flooring - pricing)

[Quote to replace sagging shelf](#) (Oliver Fity)

[Workshop seating plan](#) (Maurice)

[Freezer costed proposal](#) (Lucy Williams Moore)

[Quote for single door freezer](#)

In February, MC discussed the state of financials and what our priorities are. The Strategic Plan has two main directions underpinning the proposal: Financial Stability through increased sales; and Strengthening the Alfalfa House Community

Stevie suggested the key aspect is accessibility. The previous shop design was undertaken with an architecture firm in conjunction with 3rd year students.

Catherine noted it was also a drive to get new members at the time.

Maurice mentioned that in 2003 there was a decision to only have a one off joining fee.

Vanessa explained that her design work was originally driven by the WH&S report, however, she could see there are additional improvements that could be made. Issues noted included:

- poor exposure through the front window
- poor signage
- front window full of items that weren't enticing (e.g. toilet paper), doesn't sell the shop
- shopping process intensely confusing
- first thing you see is not for sale
- POS desk doesn't meet Australian standards
- hard to get to the fridges.
- difficult to get into the small jars. No enough bench space. High likelihood of spillage
- floorspace layout- products not in adjacencies
- presented as a shop in decline- old, tired and damaged. Not positive
- lack of storage at the front of house
- packaging at the back of the shop
- lack of signage and clear lines of sight. Can't see the packaging, oils, sink. Should be able to get a sense of the whole shop, but you don't
- walkways are too tight. Flow needs to be improved.
- flow for impulse sales needs to be improved. Depends on where you put them,

Vanessa said she asks clients: what has the most margins, what do you sell most of, and what has the most potential? She looked at sales with Maurice. For example, toilet paper had gone up, but you can see in sales that that is from positioning. Nuts had gone down since they were relocated to the back of the shop. She consulted with the staff and observed shoppers in the space and everything in the design is there because of feedback, sales and shopper experience.

Catherine asked what shelf space do we have now? What will we have in the future?

Vanessa did not know the space measurements but said there was no loss of shelf space in the design. Catherine asked for the return on shelf space.

Vanessa: said that there was closed wall space, one tall unit now against the wall, condensed the space in the tall units. Figures could be calculated for shelf space, but currently there is lots of wasted space.

Action item: Vanessa to get figures on the return on shelf space to Catherine.

Sarah asked how mistakes like 4 jars to a shelf won't be made again and raised concerns about the concept of impulse buying put forward by Vanessa.

Vanessa said that the proposal is based on a question of survival. Depending on where you put things, they can become staples. Could think strategically, eg. put fruit and veg in the positions that will entice certain behaviours.

Matt asked about floor units 3 and 4 (sweets and snacks; fruit and veg), in particular if they would be mobile when fully stocked?

Vanessa confirmed they would be moveable on industrial castors.

Matt noted that the front window was shown still packed with produce. Vanessa said it was just a drawing to show an example of how much produce can be fitted in.

Paul noted that some of the flooring isn't stable and asked about the integrity of the sub-floor. The consultant was not engaged to look at that, but Vanessa advised that units can be adjusted so they are flat.

Maurice said he is in discussion with the real estate about the floor. They are aware that we want to address this issue. It is a high priority to fix as we recently had a volunteer twist her ankle.

Emma asked about the flow at the POS, in particular if there would be sufficient space on the right for your things, as the customer works right to left and the staff member works left to right. Vanessa advised there would be boxes under the bench retrievable by staff or members.

Maurice said the new POS would be a safer space to put your basket.

Catherine noted that previously the landlord wouldn't fix flooring. Stevie added the whole western side of the flooring is not stable, but that we don't know if it is rot or something else. Vanessa suggested looking at our rights as a tenant.

Maurice said that the landlord is happy to pay for the structural element in the back room as we paid for the top beam. Maurice thinks the landlord would be amenable to fixing mould, issue with the ceiling, leakage issue, and door frame in the office also need fixing.

Maurice said that Oliver's quote excluding the floor and the freezer is \$23,000, while the other quote is for \$40,000. There is also a quote for \$3,300 for fixing bowing shelf under the legumes shelf. The metal return next to the sink would go. Miso to the left of the sink, and the freezer will go to the right of the sink.

\$3,800 for the freezer. \$680 for the floor. Just over \$30,000 for the whole re-fit.

Proposed funding sources include \$19,000 raised in 2017 from the Annual Subscription Fee (ASF).

A further \$26,000 would be raised by the ASF by Jan next year.

Maurice said there is a new grant requesting \$5,600, and also that it is likely we will get the grant through Jenny Leong. We will find out in mid/late October.

Catherine mentioned the importance of contingency pricing, plus that and electrical would cost \$3,300.

David: CTP grant, had added these figures. #1, POS, #2, replacing all refrigerators.

Catherine: were looking at a new fridge.

Bruce: what is the proposed disruption to the shop?

Maurice: working with Ollie, he knows the shop. Potential to work outside of office hours.

Ollie: would work from 7pm. Build off-site, then install. Would give 2 weeks for bump in.

David asked if we could just implement the POS section changes to fix the WHS.

Vanessa said that should not occur. If you take out POS, there is nothing to put that product onto. Partial fix won't fix the sales objectives of being viable and sustainable financially.

Bruce: what if there is a fault eg. sub-floor issue? What is the contingency plan.

Vanessa: subfloor issue needs to be sorted first.

Katherine: what is the return on the investment in profit?

Maurice: current workshop space is 8-10. New would be 20. 1 year. Listed in the proposal.

Including the freezer, workshops, and veggie boxes. 40% profit on workshops.

Katherine: concerned that he has listed revenue, not profit. Missing some information

Maurice: freezer is profit, will add workshop. \$14,400/year, 6,500 = profit.

No estimation on additional sales for moving items.

Vanessa: could reverse the data, look at projections. Also need to look at the risk/cost of not doing anything. Joinery is falling apart, will cost in reduced members, and work health and safety items. **(Action item)**

MC: Thank you for all the detail, need a little more before making a decision.

Katherine: will collate a set of questions. **(Action item)**

Proposal: That approval is given to proceed with the shop redesign, based on indicative costings and funding options provided.

Not carried; action items pending.

Meeting closed at: 9:10pm

Post-meeting check-in

Next meeting date: 26 September 2017

FY2017 NUMBERS

Our YTD numbers look like this with comparables for the last two years:

	2017	2016	2015
Revenue	1,174,331	1,193,022*	1,323,854*
Cost of Goods	735,651	760,441	837,496
Operating Expenses	451,912	515,576	519,229
Donations/Grants/Interest Income	5,869	17,888	12,436
Annual Subscription Fees	18,596	0	0
Joining Fees	11,660	13,800	17,980
Profit (Loss)	22,893	(39,978)	(2,579)

*With a \$22K write-off of sales and till variances in June 2016, and an \$11K write off in 2015. How much of these losses belong to prior periods is not clear.

So, as we have discussed, revenue is down, but because of our cost-cutting and the annual subscription fee and donations, we are looking at a profit at year-end. The estimated net profit is \$22,893.

We need to discuss with Zahra whether the grant money spent in 2017 (received in 2016) affected the FY2017 numbers (increased operating expenses)?

So, this is a better result but not fantastic.

JULY NUMBERS / Dashboard

Please note that these are estimated numbers and have not been finalized with our book-keeper.

We recorded \$104K in sales (vs. \$101K last year vs. \$110K the year before).

We show a net profit of around \$1.9K for the month. Note that: (i) we booked \$2.5K in annual subscription and joining fees; (ii) purchasing was \$69K, higher than the average 2017 monthly at \$61K.

So, in actuality, we are looking at, maybe, an \$7.4K profit for the month.

Maurice's overall take is that for the month of July: we saw a better July than in previous years because of the plastic-free July campaign; extra 30 people joined (compared to our annual average); an additional \$3K in revenue from plastic-free July; we also saw additional revenue from the veggie boxes and workshops. Positive month.

Sales Variance (POS v. bank) at -\$615 for the month. We will need to investigate this in order to try to reduce this number.

Maurice continues to work with staff to reduce these Sales Variances, and we are seeing positive results. Maurice is continuing to work with a volunteer (Bill Garvis) to create a process for resolving these variances at the end of day and redesign the Daily Balance Sheet: so that staff are able to complete a full till reconciliation when they close.

FORENSIC ACCOUNTING

Sax is waiting to meet with Maurice / Jonny to review the data.

From November: We continue to work with RGL Forensics in order to sort out the \$20K loss we recognized in 2016. Recently (with the help of Katherine Lustig's partner, Sax) we were able to access our historical financial data on MYOB (July 2013 - May 2014). This has been forwarded to RGL Forensics; and they have put together our monthly balance sheets (July 2013 to Present) which shows the Clearing Account - Cash line item. It is here for your perusal - <https://drive.google.com/open?id=0B2CzrZkqx6HpQjZtVlhaQ29xb2QzaURFZzlhodzNoR0JwWU1v>

At this time, RGL Forensics does not see any easily discernable pattern in this data which would reflect theft. The balance in the Clearing Account - Cash fluctuates in a manner which seems unrelated to staffing. We have asked Sax for additional help retrieving data from our historical financial data. When we get that information, Maurice is going to take a closer look at the daily revenues to see if we can get some clarification with respect to the movements in the Clearing Account.

We still need to pursue variances in the recent past; Maurice/Julia have done some good work on November's numbers which may prove helpful for July - October. Maurice will look at July - October over the holidays. Maurice has seen a lot continuing issues with the POS reporting and closing out of the tills. We continue to see issues with the doubling up of a day's sales (a mistake at the till). Maurice is addressing these issues with procedures for staff on till handling.

INSOLVENCY ALARM

We discussed when we should be concerned about immediate insolvency. We all recognize the formal position that it is the point at which we would be unable to pay our debts as they come due. We looked at the current balance sheet, and we estimated that our current buffer is about \$76K. This figure is based upon the Current Assets less Liabilities; basing inventory value at cost; estimating that inventory is at around the same value as at June 30, 2017.

CASH FLOW BUDGET/FORECAST

Maurice still feels comfortable with his fortnightly budgeting at the moment. Maurice is budgeting about \$18K a week on stock purchases. We are comfortable with our cash position for the next month. We are looking at the following expenses in August: shed costs (\$800), increased staff costs related to implementing inventory tracking (<\$2,000).

POS WORK

This is subject to a current grant application.

Catherine O'Keefe is taking a lead on this. Catherine, Maurice and Jonny are going to meet to discuss finding a new POS.

INVENTORY TRACKING

We've hit a slight roadblock in entering sales price; we have three different sales prices; the template we were using does not allow for more than one sales price. Maurice is trying to resolve this; in the meantime, we continue to collect the data in a format that is easily uploadable to Xero, so that we should be ready to go when this is resolved.

Maurice is saying we should look at the inventory modules of the POSs we are considering. Jonny/Maurice will discuss with Catherine.

ACCOUNTING FOR WORKSHOPS/VEGGIE BOXES

The payment for workshops and veggie boxes is delayed by a couple of days. This may cause issues when these dates straddle the end of the month. Subject to running this by Zahra, we plan on reporting veggie boxes and workshops as sales at the end of the month in which they occur. If the money is received in the next month, then we may have a timing issue. TBD with Zahra.

Profit & Loss

ALFALFA HOUSE COMMUNITY FOOD CO-OPERATIVE 1 July 2017 to 31 July 2017

	31 Jul 17	31 Jul 16	31 Jul 15	31 Jul 14
Income				
Cash Sales Deposited to bank	-	433	-	-
Daily Balance Sheet Variance	-	-	-	(625)
Sales - Ex GST	89,368	88,175	96,162	98,882
Sales - GST	14,943	12,341	14,445	12,800
Sales variance - POS to bank	(615)	-	-	-
Till Variance - Cash	-	-	(168)	(877)
Vouchers Claimed	-	-	-	(100)
Total Income	103,695	100,949	110,439	110,080
Less Cost of Sales				
Groceries	48,620	40,826	60,301	56,133
Less: Closing Inventory	-	-	-	(58,710)
Opening Inventory	-	-	-	58,710
Produce	20,066	20,706	21,501	22,386
Total Cost of Sales	68,686	61,532	81,802	78,520
Gross Profit	35,009	39,418	28,637	31,561
Plus Other Income				
Annual Subscription Fees	636	-	-	-
Interest Income	85	74	102	178
Joining Fees	1,345	960	1,380	1,640
Workshop Fees	402	-	-	-
Total Other Income	2,469	1,034	1,482	1,818
Less Operating Expenses				
Administration Expenses				
Accounting & Audit Fees	-	-	(6,500)	(6,500)
Advertising & Marketing	554	-	-	-
Bank Fees	-	3	-	65
Bookkeeping Fees	1,600	2,556	3,000	3,000
Computer & IT Maintenance	-	500	960	480
Computer Expenses	162	-	-	-
Depreciation	801	816	855	602
EFTPOS Fees	809	767	783	561
Fines and Penalties	-	-	104	-
Licences	206	117	427	113
Pest Management	-	-	-	345
Printing	-	-	-	140
Recruitment Fees	110	-	110	-
Repairs & Maintenance	538	789	694	88
Room Hire	-	-	80	-
Shop & Office Equip < \$1000	122	921	87	149
Software [62830]	-	-	70	64

Profit & Loss

	31 Jul 17	31 Jul 16	31 Jul 15	31 Jul 14
Staff Amenities	36	-	-	-
Staff Amenities [62820]	27	-	-	-
Stationery & Office Supplies	113	-	255	412
Subscriptions	93	85	112	290
Travel Expenses	-	-	23	-
Website Hosting	-	-	-	133
Total Administration Expenses	5,171	6,554	1,060	(58)
Communication Expenses				
Internet	-	64	64	64
Telephone Expenses	21	64	158	61
Total Communication Expenses	21	127	222	125
Employment Expenses				
Annual Leave - Movements	1,011	2,198	183	2,612
Contractor Expenses	-	-	-	817
Long Service Leave Expense	-	-	-	(5,244)
Superannuation Expense	2,245	1,954	1,966	2,232
Wages & Salaries Expenses	23,634	22,185	20,838	20,500
Total Employment Expenses	26,890	26,337	22,988	20,917
Facility Expenses				
Cleaning Expenses	36	1,891	1,836	-
Electricity Expenses	-	-	1,852	(205)
Gas Expenses	70	-	-	-
Recycling Fees	-	-	200	232
Rent	3,314	3,259	2,762	2,754
Rubbish Removal	-	136	351	93
Total Facility Expenses	3,420	5,286	7,001	2,874
Insurance Expenses				
Business Insurance	-	-	4,262	986
Workers Comp Insurance	-	562	805	735
Total Insurance Expenses	-	562	5,068	1,722
Total Operating Expenses	35,502	38,865	36,339	25,579
Operating Profit	1,976	1,587	(6,220)	7,799
Non-operating Expenses				
Other Non-operating Expenses				
Suspense	-	-	222	-
Total Other Non-operating Expenses	-	-	222	-
Total Non-operating Expenses	-	-	222	-
Net Profit	1,976	1,587	(6,442)	7,799

Balance Sheet

ALFALFA HOUSE COMMUNITY FOOD CO-OPERATIVE As at 31 July 2017

31 Jul 2017 31 Jul 2016

Assets

Current Assets

	31 Jul 2017	31 Jul 2016
Bank Accounts		
Bank Account - Debit Card 249	1,372	24,901
Bank Account - Expenses - 250	43,944	7,744
Community Access	22,034	-
Total Bank Accounts	67,350	32,645
Inventory		
Inventory year end	55,176	71,228
Total Inventory	55,176	71,228
Other Current Assets		
Bond on rental property	3,585	-
Total Other Current Assets	3,585	-
Till Box		
Float Till Drawer	300	300
Front Till Change box	518	466
Total Till Box	818	766
Undeposited Funds		
Electronic Clearing Account	-	(656)
Undeposited - Cash	4,550	3,499
Undeposited - Debit/Credit Card Funds	2,124	9,947
Total Undeposited Funds	6,674	12,791
Total Current Assets	133,603	117,430
Non-current Assets		
Containers & Scoops	3,889	4,576
Fixtures & Fittings	11,886	8,798
Improvements	8,695	10,880
Shop & Office Equipment	18,348	20,833
Software	1,123	1,498
Total Non-current Assets	43,942	46,584
Total Assets	177,545	164,014

Liabilities

Current Liabilities

	31 Jul 2017	31 Jul 2016
ATO Liabilities		
GST	(3,135)	(1,390)
ICA - ATO	-	4,872
PAYG Withholding Payable	9,123	-
Total ATO Liabilities	5,989	3,482

Balance Sheet

	31 Jul 2017	31 Jul 2016
Employment Liabilities		
Annual Leave Provision	14,433	18,153
Long Service Leave Provision	6,564	3,598
Superannuation Payable	2,245	3,116
Wages Payable - Payroll	-	(944)
Total Employment Liabilities	23,243	23,923
Payables		
Trade Creditors	29,015	40,563
Total Payables	29,015	40,563
Total Current Liabilities	58,246	67,968
Non-Current Liabilities		
Other Non-Current Liabilities		
Rounding	-	31
Total Other Non-Current Liabilities	-	31
Total Non-Current Liabilities	-	31
Total Liabilities	58,246	67,998
Net Assets	119,298	96,016
Equity		
Current Year Earnings	1,976	1,587
Retained Earnings	117,323	94,429
Total Equity	119,298	96,016

Website working group

August 2017 report

Veggie box pilot

- The veggie box delivery pilot has been successful, and we plan on rolling it out to all customers. However, before we do so we need to make several improvements to the current website implementation.
- These improvements include:
 - The ability for customers to order both delivery and collection boxes from within the same system
 - The ability for AH to limit the number of delivery and collection boxes available for purchase on each date
 - The ability for AH to restrict sales of delivery veggie boxes to customers outside of a 5km radius (via a postcode check)
 - The ability for AH to charge different delivery costs depending on customer location
 - The ability for both delivery and collection customers to pay online via PayPal (collection customers will also be able to optionally pay in-store)
 - To only permit delivery customers to order 'add-ons' for their veggie box (such as bread, eggs, milk). Collection customers will have to purchase these in-store.
- We are currently working on these improvements and hope to go live with our new system on September 8th, however there is the potential for this to slip due to other commitments. We will endeavor to communicate and delay asap to the MC.

Other

- Our next major website initiative will be to investigate allowing customers to place recurring orders for veggie boxes. We do not yet have a timescale for this
- New working group member Kirstin Silltoe will additionally be conducting a thorough review of the website, and providing recommendations for improvement. We will make the report available to the MC on its completion
- As always, we welcome feedback from the MC on the website

ALFALFA HOUSE – ORGANISATIONAL SHOP STRATEGY

Overview

Alfalfa House is known as the oldest food co-op in Sydney and is the leading organic wholefood store in the Newtown/Enmore area. It has approx. 1,400 current and active members and close to 80 regular volunteers with an additional 8 paid members of staff. The shop is in its 3rd year of a five-year lease with an additional 5-year extension available.

The following Objects govern the organisation:

- a. to provide a retail source of whole foods so that members may have some control over the sources of their food supply;
- b. to provide information on and promote the use of
 - i. low-cost, ethically-produced and packaged whole foods,
 - ii. cruelty-free foods,
 - iii. vegetarian foods,
 - iv. vegan foods,
 - v. organic foods and,
 - vi. genetically-modified-free foods;
- c. to run an ethical, not-for-profit business;
- d. to minimise resource wastage and, hence, encourage reuse and recycling
- e. to support other cooperatives whose objects are similar or related to the objects of the cooperative; and
- f. to stimulate community development, foster community spirit and promote sustainable living.

Financials

Over the last 3 years the co-op has experienced a decline in sales due to a number of factors:

- Shop redesign in Feb/Mar 2015
- Increased competition in the local area
 - Dr Earth under new management
 - Naked Foods
 - Addison Road markets
 - Village Wholefoods in Marrickville
 - Taste Organic in Enmore
 - Expanding organic ranges in the main supermarkets
- Lack of financial (high overheads due to cleaners, IT support) and stock controls (no just in time ordering)
- Absence of workshops (due to shop redesign in Feb'15), open days and community outreach during 2015/16
- Lack of clear marketing and social media presence/plans in 2015/16

In the 2015/16 the organisation reported a (\$39k) loss and was experiencing a decline in new members and a higher turnover of members leaving the organisation.

Strategic Focus

Alfalfa House is operating at its best when it lives and breathes the objects that govern the organisation. Furthermore, we need to look to our history to guide us on what works best for the organisation, in terms of financial performance as well as community engagement. Over the last few years, the organisation lost its way and stopped doing those things that help define us and play to our competitive advantage.

- We are the pioneers in Sydney's Inner West as the place to shop for package free, organic wholefoods.
- At the heart of our organisation is our volunteer workforce, whom provides us a committed and cost effective resourcing to ensure we can provide affordable produce and groceries to our customer base.
- We are more than a retail grocery store; we are place where you can learn/teach/explore new and different ways to eat/live/play. This is central to our point of difference, we are an experience and destination in which you can discover and develop a part of yourself you never new existed.
- Community spirit, cooperation and collaboration help elevate us to a place where we have previously excelled through our community outreach and development.

Organisation Strategic Goals and Annual Plan

Over the last two years the MC has developed [organisational strategic goals](#) and underpinned by an [annual plan](#). These documents are central to the overall operation plans of the organisation, however they do not include resource staffing plans.

Highlight of Achievements in 2017 (as at 31 July)

Achievement	Description	Strategic Direction
Annual Subscription Fee	Re-instated a \$20 (ncl GST) annual subscription fee	A
Hired 5 new staff & expanded responsibilities	Significant changes to personnel, including recruitment, training and expansion of new roles	B & G
Completed 15/16 CBP Grant	Bulk liquids shelving, new signage, air-con maintenance	A & B
Improved volunteer systems & engagement	New whiteboard to manage volunteer roster. Increase in no. of volunteers (e.g. new closing shift)	E
Improved marketing	Our social media is leading the pack. Our Instagram following has almost tripled	A, F & I
Improved window display	Reorganised placement of products to more effectively display what we are about	B
New Website		F & I
Introduced new products/services	Kombucha on tap, Veggie Box Delivery, workshops	B & D
Placement of products in the shop	Reorganisation of products around the shop to improve high margin product sales and traffic flow	B
Re-introduced workshop space	Added castors to fruit&veg stand to seat 8-10 people	D

Produce Buyer Strategy

Objectives:

- To source fresh Australian seasonal produce, giving priority to farmer direct produce.
- To provide produce that is certified or non- certified organic, free of any insecticides and pesticides.
- To source produce primarily from the Sydney basin and regional NSW to minimise food miles.
- To provide the highest quality of seasonal produce, when it is at it's most affordable pricing.
- To source the stable fruit and vegetables when available. We aim to have range of varieties of these staples at a range of price points (e.g. carrots, onions and potatoes)
- To source produce free from plastic packaging.

- To source a diversity of produce and educated our members on unfamiliar heritage varieties and the seasonal nature of produce.

We currently source our produce from:

- 1. Certified organic produce, direct from farmers located in the Sydney basin and regional NSW.**
- 2. Insecticide and pesticide free produce, direct from farmers in the Sydney basin and regional NSW.**
- 3. Certified organic produce through wholesalers from the eastern states of Australia.**

At present we get produce directly from the following:

1. certified organic produce direct from farmers located in the Sydney basin and regional nsw.

- Anthony Wallis (oranges from Colo River) Cert. Org
- David Flinter/Hand n Hoe – Comboyne (garlic and turmeric) Cert. Org
- MoonAcre (Potatoes, Greens in Spring Summer not to forget the remarkable Apples) Fitzroy Falls, Southern Highlands, Cert Org.
- Block Eleven Organics (greens) Hawkesbury Cert Org. – delivered by volunteers from Eveleigh Market
- Green Patch Seeds, Old Bar near Taree – delivered by Volunteers

2. Chemical free produce direct from farmer in the Sydney basin and regional nsw.

- Margin Mushroom Gosford chemical free – delivered by volunteer Roger direct from Eveleigh Market
- Colin Amos, Comboyne (Avo, Citrus and much much more) chemical free
- Pocket City farm

3. Certified organic produce through wholesalers from the eastern states of Australia.

- Ooooby (surplus from their Veg Box Scheme) includes Mahbrook, Kurrawong, Skein Family Apples/Pear Cert Org/chemical free.
- Back to Eden (min order \$500) Back to Eden, looks after us Mon, Wed and Friday - we place the largest order with them.
- Eco Farms (min order \$250) – they own Taste Organics Eco Farms, delivers Monday and Friday, and have a wider variety of fruit and veg, ie the Jazz Apple. They have many more farms on their books, including NSW farmers spectacular like Kurrawong, Mahbrook and Joy Price. Farms that will not deliver directly to us (it's a hassle, the small amount we can take at a time, and no way of delivering)

Hours

The Produce Role is current standing at 18 hrs a week. We are currently only using 16.5 since Sept 2016.

History

In 2012 under the stock coordinator of Carly the role rose from 19 till 22 hrs. At that time we had a few more farmer direct contacts. Carly was paid to go to markets to source new farmers. She also organized Farm Visits.

We have over the past years lost several chemical free farmer direct produce (ie. Field to Feast, Common 2 Us, Pickle Creek Farm), as it becomes to hard to both farm on land they don't own, battle the weather and then battle the traffic for hours to deliver to us)

Groceries Buying Strategy

Objectives:

- To provide quality products at various price points
- To source products that adhere to the Alfalfa House objectives:
Low-cost, ethically produced and packaged wholefoods; Cruelty Free Foods; Vegetarian Foods; Vegan Foods; Organic Foods; and GMO free foods
- To give priority to products that support, as much as possible, local, regional and Australian producers
- To provide customers with education about the products in store in order to support the ethical and sustainable food industry as well as maintain financial security for the Coop.

Product Sourcing:

Products are sourced based upon their ability to meet the criteria of organic, GMO free, fair and sustainable production (including treatment of workers, environment, community etc.) 'local' (at least Australian), chemical free and cruelty free. Not all products are able to meet all these criteria and will be assessed on a case-by-case basis.

Replacement of existing products with higher quality items that incur a higher cost will occur on a trial basis, while still holding the less expensive item. Social media and in store promotion will be carried out in order to educate customers, and then the product will be assessed based on sales and customer feedback. The higher quality product may then be kept as a replacement product, as an alternative product, or discontinued. Return of high value products that were discontinued due to financial stress or unavailability, will be based on customer demand and coupled with social media promotion and, where possible, in house workshops to educate customers and increase sales.

Process for discontinuing products:

If a product is not selling well action should be taken to promote it in store (through product placement, signage, verbal promotion etc.) and via social media. If demand for the product does not increase its viability as a stocked item, it should then be assessed based on a) how much profit is made by sales vs. how much could be made by a potential replacement product; and b) whether or not product quality is maintained. Items sitting in storage for long periods, particularly if opened, will decrease in quality. Products that are light and/or oxygen sensitive will also deteriorate if left on the shop shelves for too long. When a product is discontinued interested customers should be informed that they might still make a bulk order even though it is no longer a stocked item.

Budget and Pricing:

The budget is currently set to around \$12,000 each week, which may increase or decrease slightly due to stock requirements and demand for high value products (such as nuts and bulk liquids). Products should be priced, in general, at a 75% mark up to maintain a profit margin above 30%, however each product should be individually assessed and priced accordingly. Staple items should be kept at a lower price point in order to entice new customers and support those who have less to spend. Specialty items can be held at a higher price point, however all pricing should be fair, with equal priority being given to the need to make profit as well as provide Alfalfa House members and the wider community with access to good quality affordable food.

Volunteer Strategy

The priority of the Volunteer Engagement Working Group is to develop a volunteer engagement plan. It will clarify how Alfalfa House involves its volunteers and review our current general volunteer procedures. The plan will provide direction and structure to the way volunteers are managed and supported. It will be adopted as part of the annual plan, declaring how volunteer engagement contributes directly to the Alfalfa House goals. The strategy will address the key areas of volunteer involvement as stated by Volunteering Australia in the The National Standards for Volunteer Involvement.

1. Leadership and management

The MC and staff promote a positive culture towards volunteering and implement effective management systems to support volunteer involvement.

2. Commitment to volunteer involvement

Commitment to volunteer involvement is publicly declared in the Alfalfa House annual plan.

3. Volunteer roles

Volunteers are engaged in meaningful roles, which contribute to Alfalfa House purpose, goals and objectives.

4. Recruitment

Potential members are provided with relevant information about the organisation, the volunteer role and the training process.

5. Support and development

Volunteers understand their roles and gain the knowledge, skills and feedback needed to carry out their role.

6. Workplace safety and wellbeing

The health, safety and wellbeing of volunteers are protected in the workplace.

7. Volunteer recognition

Volunteer contribution, value and impact is understood, appreciated and acknowledged.

8. Quality management and continuous improvement ‘

Volunteer involvement is monitored and reported to the MC, staff, members and volunteers.

Shop Development

Proposal to redesign shop

At the February MC meeting the Strategic and Annual plans were tabled for discussion. Katherine, Catherine and Maurice took an action to review the annual plan and identify the most urgent priorities. Given the focus of our financial stability, we have known for the last 12 months we have a sales/revenue problem that needs urgent attention to turn our fortunes around.

As per the strategic plan, it identifies the following as area of focus:

- Strategic Direction 1: Financial stability through increased sales by:
 - A) Providing a great shopping experience
 - Strategy B - Objectives:
 - Alternative points of sale options are investigated.
 - Staff are supported and trained to provide excellent customer service.
 - The shop window and environment look inviting and engaging.
 - A plan is in place to ensure that the shopping experience we offer meets the needs of our community
 - The in-store shopping experience is accessible for new and returning shoppers.
 - The viability of online shopping is investigated.
 - The viability of delivery is investigated.
 - A comprehensive survey of members is undertaken at least once every four years.
- Strategic Direction 2: Strengthening the Alfalfa House community by:
 - D) Hosting events that facilitate belonging amongst our members
 - Strategy D - Objectives:
 - We hold at least two activities/events per month on average (To be included as part of the Managers report).
 - Find out what type of events/activities members want as part of the 4 year timed members survey.
 - Our members are empowered to be a powerful force for change in their own community.
 - Our members are empowered to develop and propose events, in collaboration with staff and MC.
 - Our AGM is a fun event that people want to attend.

In Oct/Nov 2014 the shop was refurbished through a design plan by UTS students and the members of the Shop refurbishment working group. It was widely reported on completion of the refurbishment that the ergonomics to the POS area was a concern; staff reported they were not consulted during the build phase to provide feedback. Furthermore, given the fixed nature of the design, a flexible area in which to hold workshops was no longer available.

In March 2016 a WHS assessment report was commissioned and presented by Benchmark OHS Consulting to Alfalfa House, at a cost of \$2,080. At the May 2016 MC meeting a [WHS Priorities](#) report was presented. In this report it was agreed and identified that the ergonomics of the POS sale counter was a high priority to address.

At the March 2017 MC a proposal to engage Forward Thinking Design (FTD) to provide \$7,500 work of pro-bono design work/assessment was approved by MC. The focus of the work was to focus on the following areas:

- High priority areas of need with regards to March 2016 WHS report (i.e. POS counter)
- Uneveled flooring which is currently marked with a X on the floor
- Completing the remaining items from the 15/16 CBP grant (i.e. bulk liquids shelving, sagging shelf)
- Overall retail assessment of our product placement in our shop to address our declining retail sales

I met with Vanessa Cullen from FTD and handed her the WHS report, history of our retail sales financials by product category (incl. mark-up by category). Vanessa met with our shop staff to assess first hand feedback from staff on the issues they deal with on a daily basis as well as feedback received from our customers.

In May 2016, I was introduced to Oliver Fity from the Maker Space (an existing NFP in the inner west) by one of our existing volunteers; we discussed the requirements of building a bulk liquids unit. Over the coming month he delivered an outstanding product, which has been extremely well received by all, as well as being a great marketing tool on social media. Our bulk liquids have seen a big increase in sales; we have also received 3 requests from other coops/bulk food shops to obtain the same shelving unit.

Over the last 2 months we have been working with FTD to finalise the redesign proposal, feedback was sought from the staff and changes were made to the design proposal. We have also sought feedback from the membership (between 10-15 members) and many are supportive to improve the shopping experience as well as provide more space to scoop their bulk products into their own packaging.

A final design plan has been prepared with significant attention to detail, to ensure that every existing item (jar, bulk bin, tubs etc.) has been measured and fit into the design. This is to ensure we do not compromise what we have available for sale today. The key focus of this redesign is the following:

- Address current ergonomic issues with the POS for staff
- Fix the unlevelled floor in the shop
- Ensure some new units are easily moveable to provide space to hold workshops
- Strategically place our products throughout the shop based on high margins/profitability
- Maximise available bench space for our customers
- Improve the shopping experience for our customers

We have attained 2 quotes to implement the FTD redesign proposal, one from the Maker Space – Oliver Fity and the second from the Fit Out Crew.

Financials Overview

Since Dec 2014, the shop has seen a decline in sales revenue especially in the Groceries product lines. Based on historical financial data as well as product placement in the shop, this is due to:

- High margin groceries being moved to the back of the shop (e.g. nuts & sweets)
- Poorly presented window displays
- Absence of workshops, this assists greatly to sell the products we have on offer
- Change in personnel responsible/experienced for managing our groceries strategy

SALES HISTORY

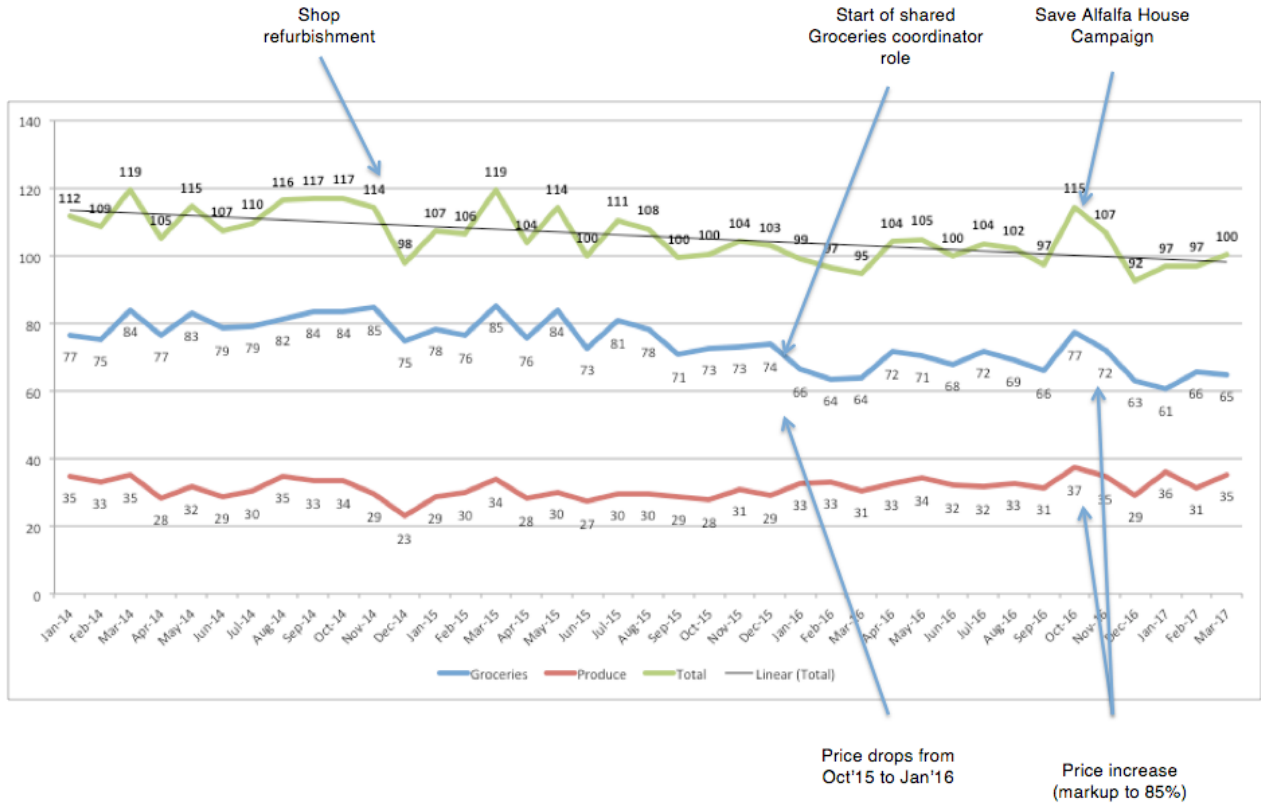

Diagram 1.0 – presented to MC in Manager’s report March 2017

ALFALFA HOUSE COMMUNITY FOOD COOPERATIVE LTD.

YoY Sales by Category

Category Super	Category	2014			2014 Total	2015			2015 Total	2016			2016 Total	YoY Change %		
		Discount %	25%	10%		0%	25%	10%		0%	2015	2016				
Groceries	fridge		36,285	125,692	20,238	182,214	34,533	125,561	19,937	180,030	27,274	113,414	17,801	158,489	-1%	-12%
	nuts and seeds		24,833	104,360	12,837	142,030	21,787	97,488	10,782	130,057	18,397	88,650	9,412	116,459	-8%	-10%
	home		12,166	53,477	13,211	78,853	13,080	55,602	21,801	90,483	11,910	48,710	20,753	81,373	15%	-10%
	edible liquids		14,720	56,783	6,742	78,245	13,488	53,616	6,798	73,903	11,889	48,772	4,699	65,359	-6%	-12%
	pre-pack		16,750	40,793	8,628	66,170	16,326	39,439	12,053	67,819	15,897	33,842	9,442	59,181	2%	-13%
	cereal		7,464	39,952	6,699	54,116	6,651	40,136	6,075	52,861	6,849	35,048	4,978	46,875	-2%	-11%
	sweets		11,820	40,965	10,943	63,729	11,026	34,271	9,742	55,039	11,446	27,485	7,000	45,932	-14%	-17%
	dried fruit		8,341	38,336	4,733	51,410	8,278	37,417	4,677	50,373	6,894	34,311	3,606	44,811	-2%	-11%
	flours and powders		7,583	36,083	6,952	50,618	7,986	31,562	5,964	45,511	7,455	27,626	4,821	39,902	-10%	-12%
	bakery		6,121	26,355	5,050	37,525	5,802	29,303	5,278	40,383	4,993	29,451	4,818	39,261	8%	-3%
	herbs-spices-teas-coffee		7,451	30,337	5,626	43,414	7,145	29,491	5,082	41,718	5,748	25,747	6,120	37,615	-4%	-10%
	grains		7,825	31,909	5,516	45,250	6,132	25,770	3,716	35,617	5,031	23,035	3,699	31,766	-21%	-11%
	legumes and beans		3,239	18,075	2,565	23,879	3,109	15,504	1,912	20,524	3,624	15,832	2,301	21,756	-14%	6%
	pasta		3,159	10,501	1,872	15,532	3,669	10,684	1,771	16,124	3,387	9,659	1,702	14,747	4%	-9%
asian		3,684	8,962	1,064	13,710	2,124	8,051	1,174	11,349	2,541	7,376	1,506	11,513	-17%	1%	
packaging		560	5,239	2,170	7,970	491	4,854	1,961	7,306	421	3,861	1,605	5,886	-8%	-19%	
snacks		1,239	4,764	1,401	7,404	676	2,425	342	3,442	600	2,114	303	3,017	-54%	-12%	
Groceries Total		173,241	672,581	116,247	962,076	162,302	641,174	119,064	922,541	144,355	574,932	104,656	823,942	-4%	-11%	
Produce	VEG		37,768	135,829	14,545	188,142	35,074	131,098	10,279	176,452	38,216	150,600	13,419	202,234	-6%	15%
	FRESH FRUIT		31,162	101,797	11,280	144,238	31,381	90,665	9,237	131,283	29,987	104,670	10,610	145,267	-9%	11%
	FRESH HERBS		5,888	21,420	2,246	29,554	6,281	22,096	1,967	30,343	5,398	21,373	2,014	28,785	3%	-5%
	VEG BOX		2,839	11,745	555	15,140	1,916	13,860	633	16,410	1,849	13,627	916	16,392	8%	-0%
Produce Total		77,657	270,791	28,625	377,074	74,652	257,719	22,116	354,487	75,450	290,270	26,959	392,679	-6%	11%	
Grand Total		250,899	943,372	144,873	1,339,143	236,955	898,893	141,180	1,277,028	219,804	865,201	131,615	1,216,621	-5%	-5%	
% of Annual Sales		19%	70%	11%		19%	70%	11%		18%	71%	11%				

Diagram 2.0 – presented to MC in Manager’s report February 2017

As at 31 July 2017 we have successfully raised \$19,233 from the Annual Subscription Fee (i.e. from existing members who are renewing their memberships), this now represents an ongoing revenue stream for AH. In other words this is effectively a new product we are selling to our members, however to ensure we continue to collect the ASF each year, we have a responsibility to demonstrate how we use these funds to the membership.

Funding

There are a number of ways in which this project can be funded and achieve a payback period in Year 1.

Background:

Analysing our historical financial data, with a keen focus on the average spend per day, average numbers of shops (trans) per day allows us to identify the problem we need to address in the simplest way.

Analysis of Sales Revenue 2015 - 2017 (YTD)

Description	Mon	Tue	Wed	Thu	Fri	Sat	Sun	Daily Average
Average per Day	\$3,265.75	\$3,088.78	\$3,273.13	\$2,886.97	\$3,360.91	\$4,642.41	\$4,542.11	\$24,458.79
Average per shop	\$32.92	\$32.64	\$32.92	\$33.17	\$34.84	\$35.22	\$36.92	\$34.22
Average trans per day	105	97	100	92	100	134	124	731
Number of sales per day needed to be 1st		10	11	16	3		6	

	Best performance since 2015 (1st)
	Second best result since 2015 (2nd)
	Worst result since 2015 (3rd)

The above table identifies:

- Saturday is the best performing day of the week since 2015, on all measures
- Saturday and Sunday is achieving the best total average spend per day since 2015
- Our average spend per transaction is highest its been since 2015
- We have a problem from Tues to Thurs and Sunday with a reduction of an average of 10 transactions per day.

Therefore the problem we need to solve is how to get 10 more transactions per day on those days that we have a problem. If we were to achieve this from a financial point of view we would add (based on the average spend per transaction) \$72,000 of sales revenue per year.

Funding Options / Sources

1. Wednesday Veggie Box Delivery service. We can deliver a maximum of 15 boxes each Wednesday night. In the current pilot we are averaging \$38 per transaction, once we go live in early September, this will address the Wednesday shortfall of 10 transactions. Potential sales revenue of \$18,240 per year (10 boxes at \$38 spend each over 48 weeks).
2. Thursday Workshops. We have kicked off our workshops series, each Thursday night 2 out of 4 weeks in each month. In mid July we spent \$200 to fit castors to the fruit & veg stand to provide a small workshop space. At present we have an average spend of \$30 per workshop with a maximum of 8-10 people in attendance. In the Shop redesign proposal we are able to expand the workshop space to 20-25 people. Potential sales revenue of \$14,400 per year (20 people at \$30 average spend). This does not take into account potential sales of products on the night of the workshop, new memberships and return customers' sales.
3. Introduce a new in demand product line. See Freezer proposal. On the basis of this costed proposal there is a significant opportunity to increase the average spend per transaction with new in demand product line (e.g. bulk organic frozen berries, coconut ice-cream and Byron Bay Tempeh) in time for summer. Potential profit of \$8,237 in year 1 (i.e. this takes into account payback of freezer purchase in year 1) and \$11,652 profit from Year 2 onwards.
4. Funds raised by the re-introduction of the Annual Subscription Fee (ASF). As at 31 July 2017 we have \$19,233 on hand in our savings account. In 2018 we will once again collect the ASF, based on our current active members of 1,463, this would equate to \$26,597 raised from the 1 Jan 2018.

5. CBP Grant proposal has been submitted to fund the new POS counter and removal of old counter to the amount of \$5,600. This option is subject to approval; funds are not available until late Oct 2017.

Proposal: That approval is given to proceed with the shop redesign, based on indicative costing's and funding options provided.

Summary of costing's:

Item	Description	\$AUD
Implement FTD proposal	See Oliver Fity quote (Maker Space)	\$22,894
Fix unlevelled floor/replace vinyl	See quote from Glenda	\$432
New freezer	See Sanden freezer quote	\$3,415
Replace sagging shelf (legumes)	See Oliver Fity quote (Maker Space)	\$3,300
	TOTAL	\$30,041



PROJECT: ALFALFA HOUSE
113 ENMORE RD, ENMORE,NSW 2042

DATE: 29/03/17

www.forwardthinkingdesign.com.au

Phone: **02 8850 4977**

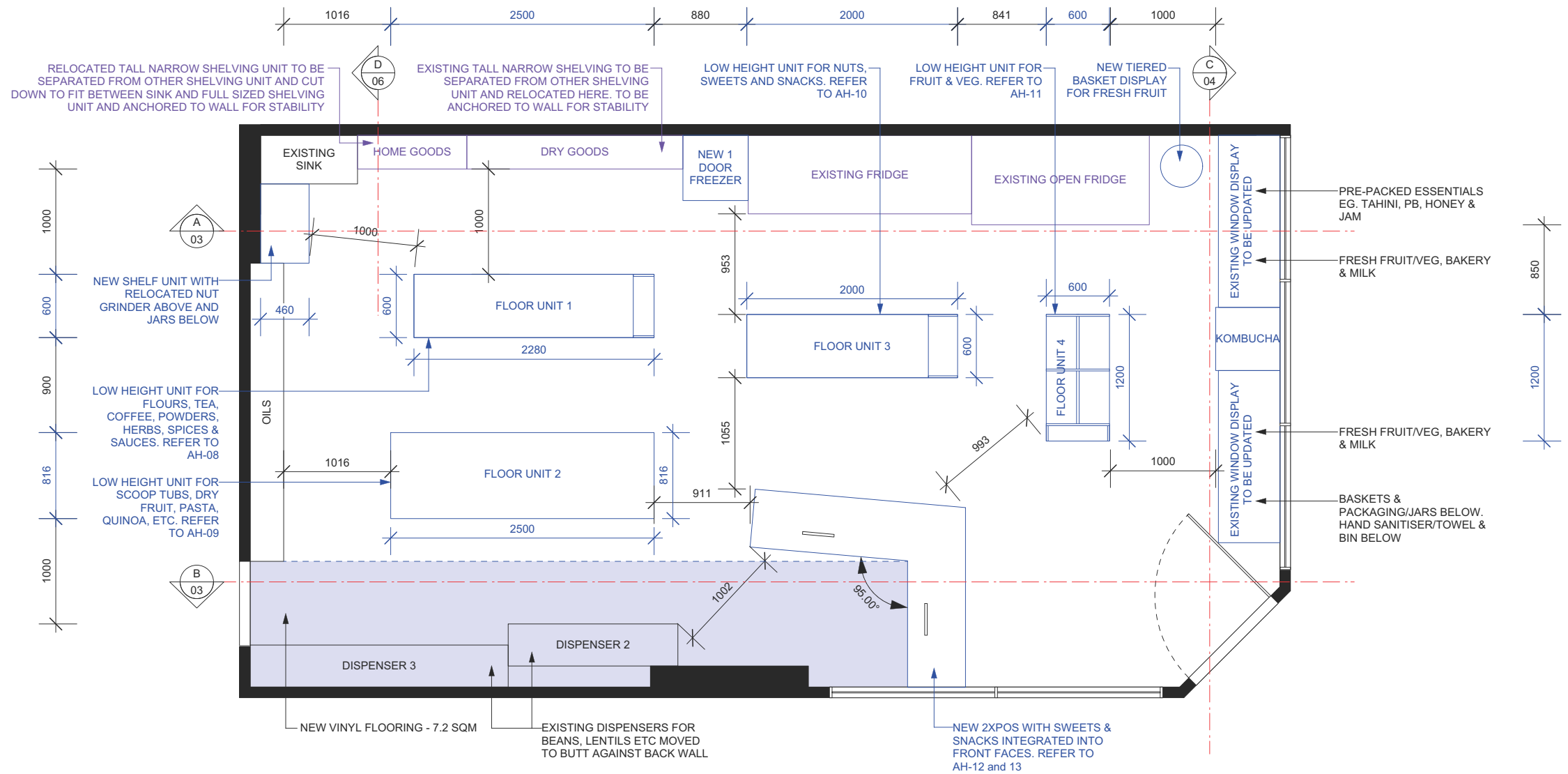

LAYOUT PLAN
Scale: 1:50

LEGEND	
	NEW
	EXISTING TO BE RELOCATED
	EXISTING TO REMAIN

NOTES:

SHOPFITTER TO VOS ALL DIMENSIONS ON SITE PRIOR TO ORDERING AND/OR COMMENCING MANUFACTURE.

SHOPFITTER TO ENSURE ALL WORKS COMPLY WITH FOOD CODE, NCC, AUSTRALIAN STANDARDS AND COUNCIL REGULATIONS.

 ABN: 27 141 981 179 8/ Suite 201, Lakeside Corporate Centre, 29-31 Solent Circuit, Baulkham Hills, 2153 Mobile Ph: 0403 867 807 Ph: 02 8850 4977 Email: vanessa@forwardthinkingdesign.com.au	NOTES: All dimensions are in mm. Do not scale off drawing. Contractors to verify all dimensions on site & inspect site conditions prior to commencement of construction. Contractors to ensure all works comply with NCC, Australian Standards and Council regulations.	Contractors to ensure strength & stability of units & also that no deflection occurs. Any variations to specifications &/or drawings must be authorised by Forward Thinking Design prior to construction. Do not substitute finishes or light fittings specified unless authorised by Forward Thinking Design. © Copyright of Forward Thinking Design.	REV.	DATE	AMENDMENT	BY	PROJECT: ALFALFA HOUSE 113 ENMORE RD, ENMORE, NSW 2042	FOR APPROVAL		DRAWN
			A	02/06/17	SINK TO REMAIN, NEW SHELF FOR GRINDER, HOME ITEMS/DRY GOOD SHELF MOVED, FREEZER SIZE CHANGED, LOW HEIGHT UNITS SIZE ADJUSTED	EH		SCALE	DATE	CHECKED
								1:50	06/07/17	VC
							DRAWING TITLE:	DRG NO.	REVISION	APPROVED
							LAYOUT PLAN	AH-02		



NEW HANGING SIGNAGE IN MAX 10mm THICK TIMBER WITH EMBOSSED LETTERING TO MATCH EXISTING OIL DISPLAY SIGNAGE. TO BE SUSPENDED FROM CEILING USING THE SIGNAGE SUSPENSION KIT FROM SHOP FOR SHOPS (\$9.45 EACH) OR LIKE AND TO BE CENTRED ABOVE CORRESPONDING DISPLAY UNIT

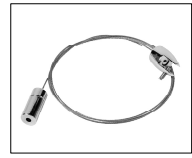

EXISTING SINK TO REMAIN

NEW SHELF UNIT WITH RELOCATED NUT GRINDER ABOVE AND JARS BELOW

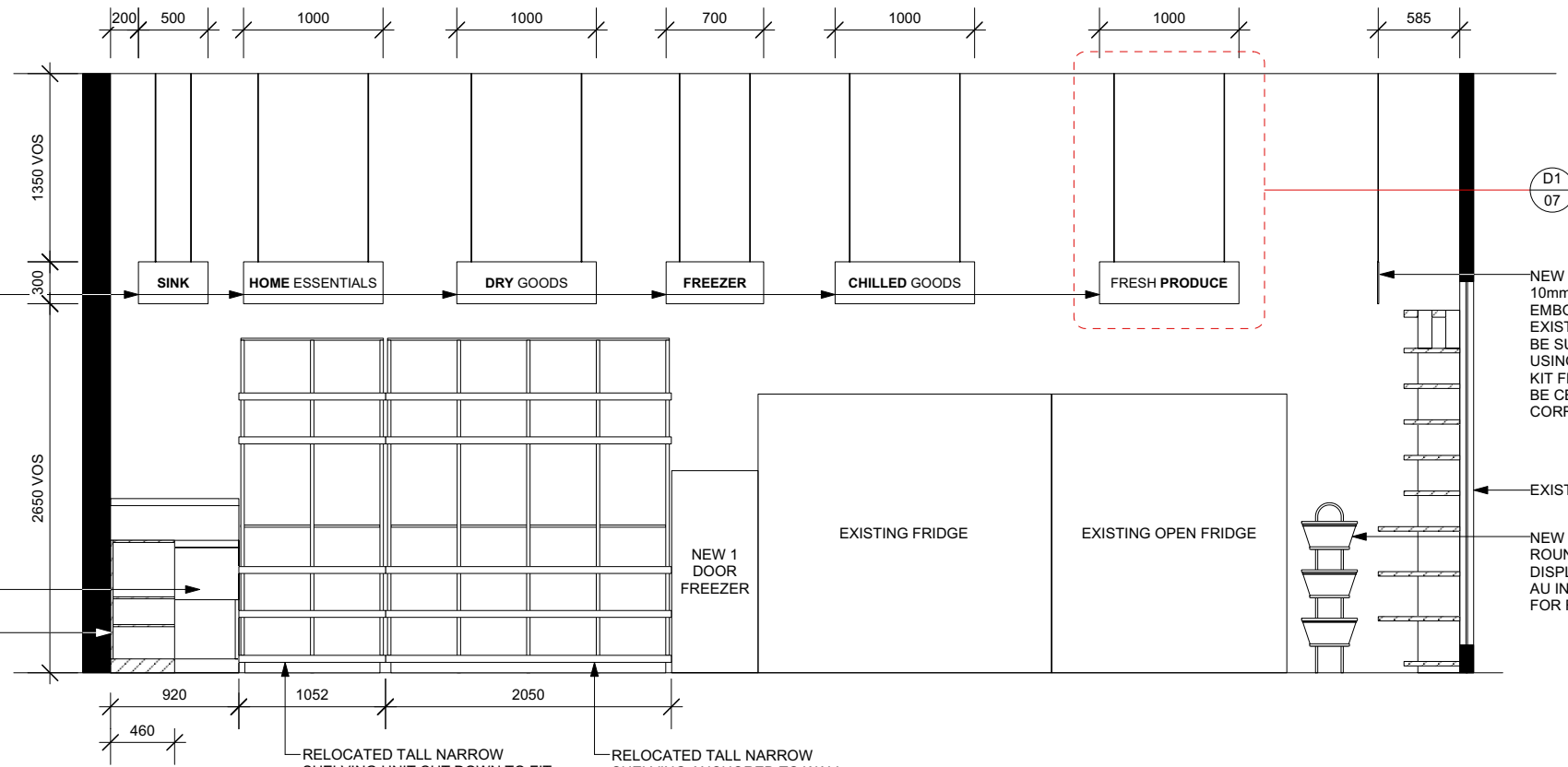

D1
07

NEW HANGING SIGNAGE IN MAX 10mm THICK TIMBER WITH EMBOSSED LETTERING TO MATCH EXISTING OIL DISPLAY SIGNAGE. TO BE SUSPENDED FROM CEILING USING THE SIGNAGE SUSPENSION KIT FROM SHOP FOR SHOPS AND TO BE CENTRED ABOVE CORRESPONDING DISPLAY UNIT

EXISTING SHOPFRONT TO REMAIN

NEW 3 TIER POLYWICKER ROUND BASKET SET FROM DISPLAYDECORATIONS.COM. AU IN COLOUR "NATURAL" FOR FRESH FRUIT



A ELEVATION A
02 Scale: 1:50

RELOCATED TALL NARROW SHELVING UNIT CUT DOWN TO FIT BETWEEN SINK AND FULL SIZED SHELVING UNIT AND ANCHORED TO WALL FOR STABILITY

RELOCATED TALL NARROW SHELVING ANCHORED TO WALL FOR STABILITY

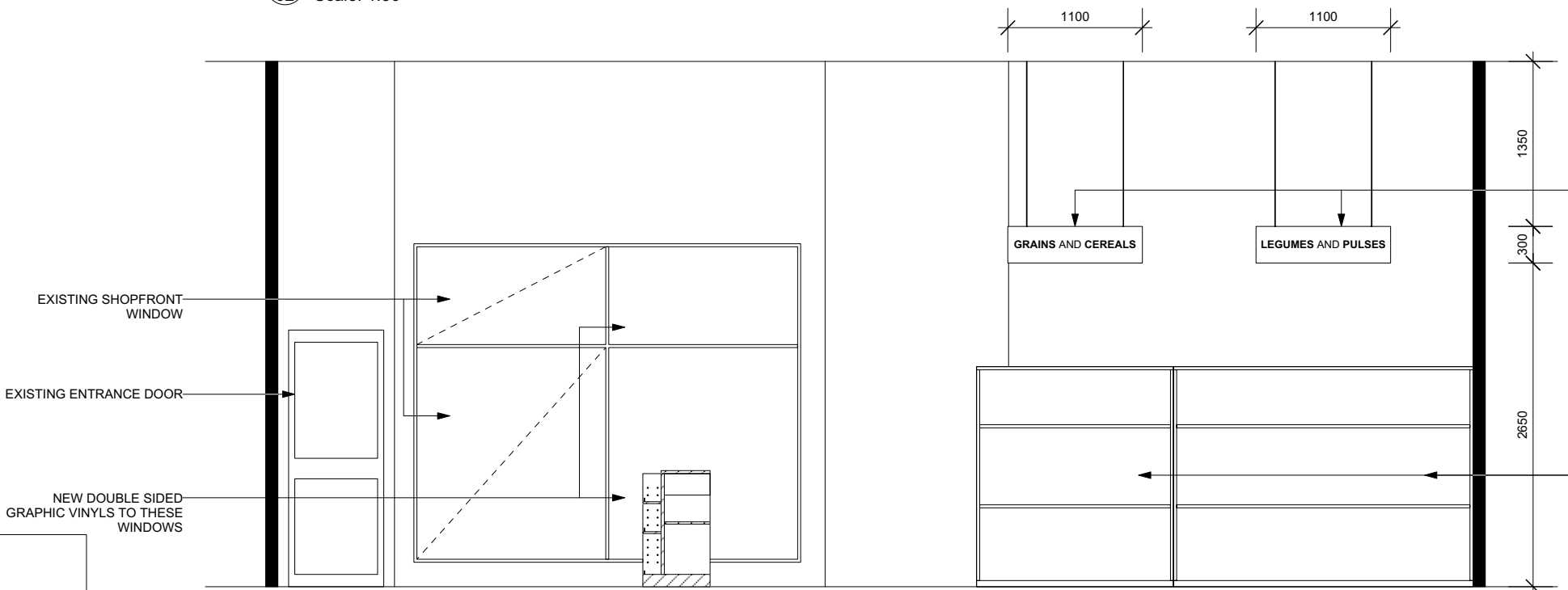

NEW HANGING SIGNAGE IN MAX 10mm THICK TIMBER WITH EMBOSSED LETTERING TO MATCH EXISTING OIL DISPLAY SIGNAGE. TO BE SUSPENDED FROM CEILING USING THE SIGNAGE SUSPENSION KIT FROM SHOP FOR SHOPS AND TO BE CENTRED ABOVE CORRESPONDING DISPLAY UNIT

EXISTING UNITS TO REMAIN

B ELEVATION B
02 Scale: 1:50

NOTES:
SHOPFITTER TO VOS ALL DIMENSIONS ON SITE PRIOR TO ORDERING AND/OR COMMENCING MANUFACTURE.

SHOPFITTER TO ENSURE ALL WORKS COMPLY WITH FOOD CODE, NCC, AUSTRALIAN STANDARDS AND COUNCIL REGULATIONS.

FD forward thinking design
A&B: 27 141 981 179
8/ Suite 201, Lakeside Corporate Centre,
29-31 Solent Circuit, Baulkham Hills, 2153
Mobile Ph: 0403 867 807
Ph: 02 8850 4977
Email: vanessa@forwardthinkingdesign.com.au

NOTES:
All dimensions are in mm. Do not scale off drawing. Contractors to verify all dimensions on site & inspect site conditions prior to commencement of construction.
Contractors to ensure all works comply with NCC, Australian Standards and Council regulations.

Contractors to ensure strength & stability of units & also that no deflection occurs.

Any variations to specifications &/or drawings must be authorised by Forward Thinking Design prior to construction. Do not substitute finishes or light fittings specified unless authorised by Forward Thinking Design.

© Copyright of Forward Thinking Design.

REV.	DATE	AMENDMENT	BY
A	02/06/17	SINK TO REMAIN, NEW SHELF FOR GRINDER, HOME ITEMS/DRY GOOD SHELF MOVED, FREEZER SIZE CHANGED, LOW HEIGHT UNITS SIZE ADJUSTED	EH

PROJECT:
ALFALFA HOUSE
113 ENMORE RD, ENMORE, NSW 2042

DRAWING TITLE:
ELEVATION A & B

FOR APPROVAL		DRAWN
SCALE 1:50	DATE 06/07/17	EH
DRG NO. AH-03	REVISION	VC
		APPROVED



NEW HANGING SIGNAGE IN MAX 10mm THICK TIMBER WITH EMBOSSED LETTERING TO MATCH EXISTING OIL DISPLAY SIGNAGE. TO BE SUSPENDED FROM CEILING USING THE SIGNAGE SUSPENSION KIT FROM SHOP FOR SHOPS AND TO BE CENTRED ABOVE CORRESPONDING DISPLAY UNIT

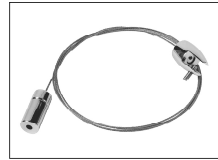

EXTRA STORAGE FOR MILK, PRESERVES, ECT.

PRE-PACKED ESSENTIALS EG. TAHINI, PB, HONEY & JAM

FRESH FRUIT/VEG

BOTTLES FOR KOMBUCHA

CANS STACKED TWO CANS HIGH

CANS STACKED TWO CANS HIGH

EXTRA STOCK LEFT IN ORIGINAL PACKAGING

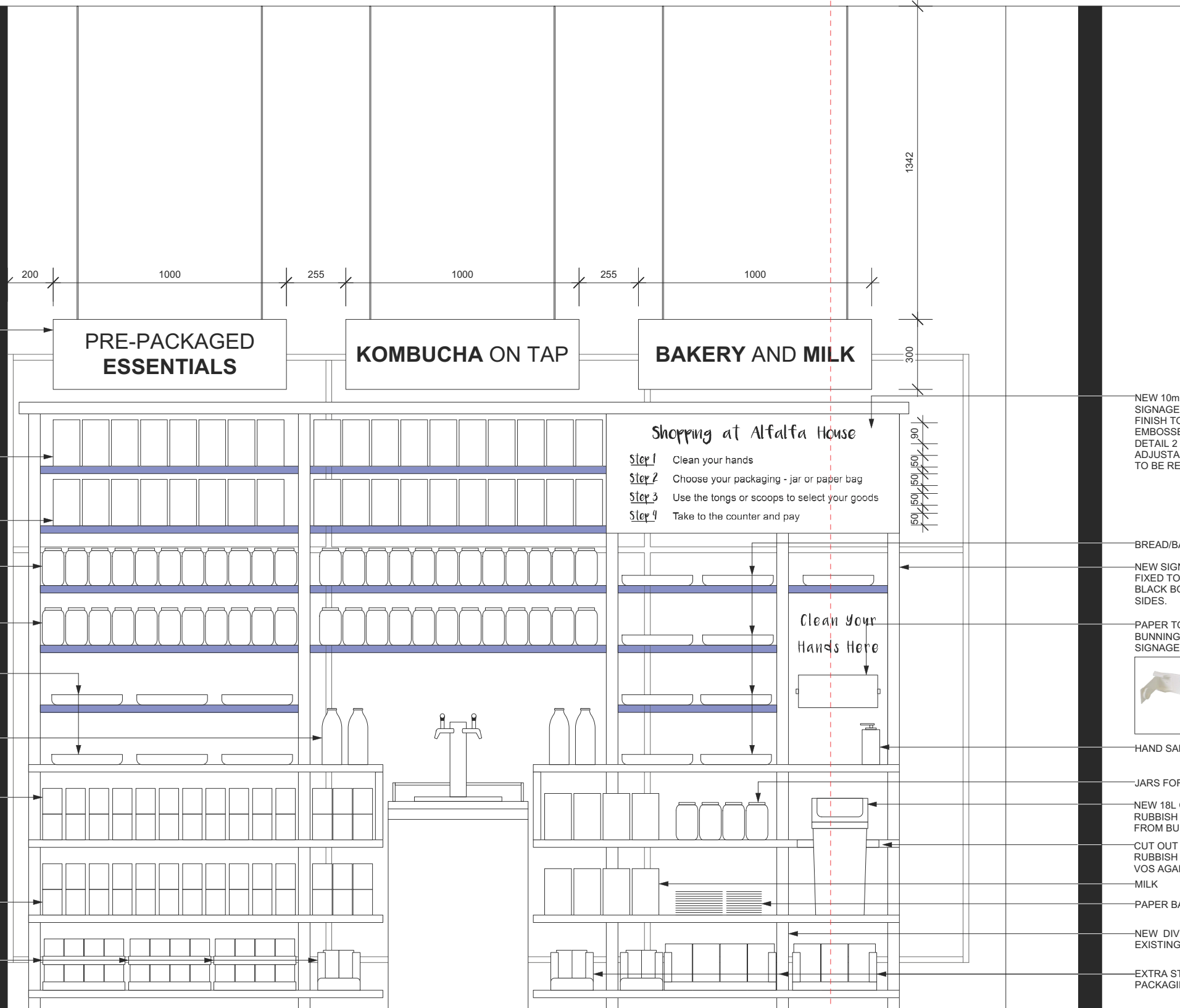

NEW 10mm THICK TIMBER SIGNAGE WITH BLACKBOARD FINISH TO INSIDE FACE AND EMBOSSED LOGO TO BACK (SEE DETAIL 2 AH-07). EXISTING ADJUSTABLE SHELVES BEHIND TO BE REMOVED

BREAD/BAKERY GOODS

NEW SIGNAGE BOARD TO BE FIXED TO UNIT AND FINISHED IN BLACK BOARD FINISH TO ALL SIDES.

PAPER TOWEL ON HOLDER FROM BUNNINGS SECURED TO NEW SIGNAGE BOARD



HAND SANITISER DISPENSER

JARS FOR SELF-SERVICE

NEW 18L CHARCOAL SWING TOP RUBBISH BIN FOR HAND TOWELS FROM BUNNINGS

CUT OUT IN SHELF TO HOUSE RUBBISH BIN. SHOPFITTER TO VOS AGAINST BIN

MILK

PAPER BAGS FOR SELF-SERVICE

NEW DIVIDER TO MATCH EXISTING

EXTRA STOCK LEFT IN ORIGINAL PACKAGING



NOTES:
SHOPFITTER TO VOS ALL DIMENSIONS ON SITE PRIOR TO ORDERING AND/OR COMMENCING MANUFACTURE.

SHOPFITTER TO ENSURE ALL WORKS COMPLY WITH FOOD CODE, NCC, AUSTRALIAN STANDARDS AND COUNCIL REGULATIONS.

C ELEVATION C
02 Scale: 1:20

LEGEND
 NEW ADJUSTABLE PLYWOOD SHELVES AT 400mm DEEP

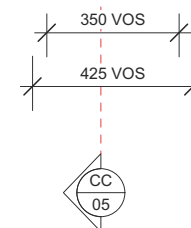

FD forward thinking design.
ABN: 27 141 981 179
8/ Suite 201, Lakeside Corporate Centre, 29-31 Solent Circuit, Baulkham Hills, 2153
Mobile Ph: 0403 867 807
Ph: 02 8850 4977
Email: vanessa@forwardthinkingdesign.com.au

NOTES:
All dimensions are in mm. Do not scale off drawing. Contractors to verify all dimensions on site & inspect site conditions prior to commencement of construction.
Contractors to ensure all works comply with NCC, Australian Standards and Council regulations.

Contractors to ensure strength & stability of units & also that no deflection occurs.

Any variations to specifications &/or drawings must be authorised by Forward Thinking Design prior to construction. Do not substitute finishes or light fittings specified unless authorised by Forward Thinking Design.

© Copyright of Forward Thinking Design.

REV.	DATE	AMENDMENT	BY
A	02/06/17	SINK TO REMAIN, NEW SHELF FOR GRINDER, HOME ITEMS/DRY GOOD SHELF MOVED, FREEZER SIZE CHANGED, LOW HEIGHT UNITS SIZE ADJUSTED	EH

PROJECT:
ALFALFA HOUSE
113 ENMORE RD, ENMORE, NSW 2042

DRAWING TITLE:
ELEVATION C

FOR APPROVAL		DRAWN
SCALE 1:20	DATE 06/07/17	EH
DRG NO. AH-04	REVISION	VC
		APPROVED

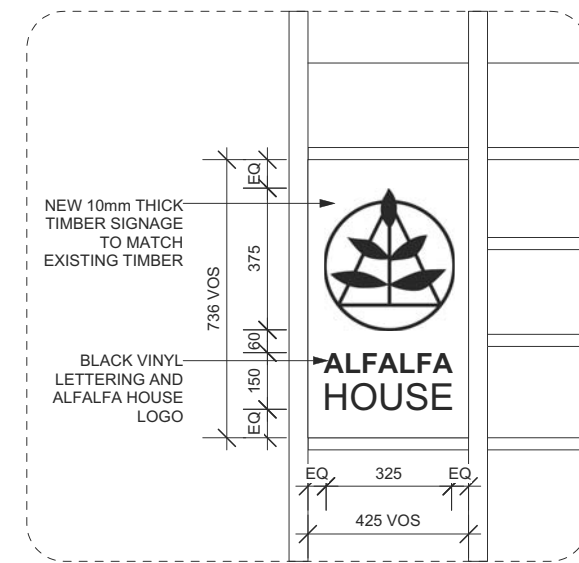
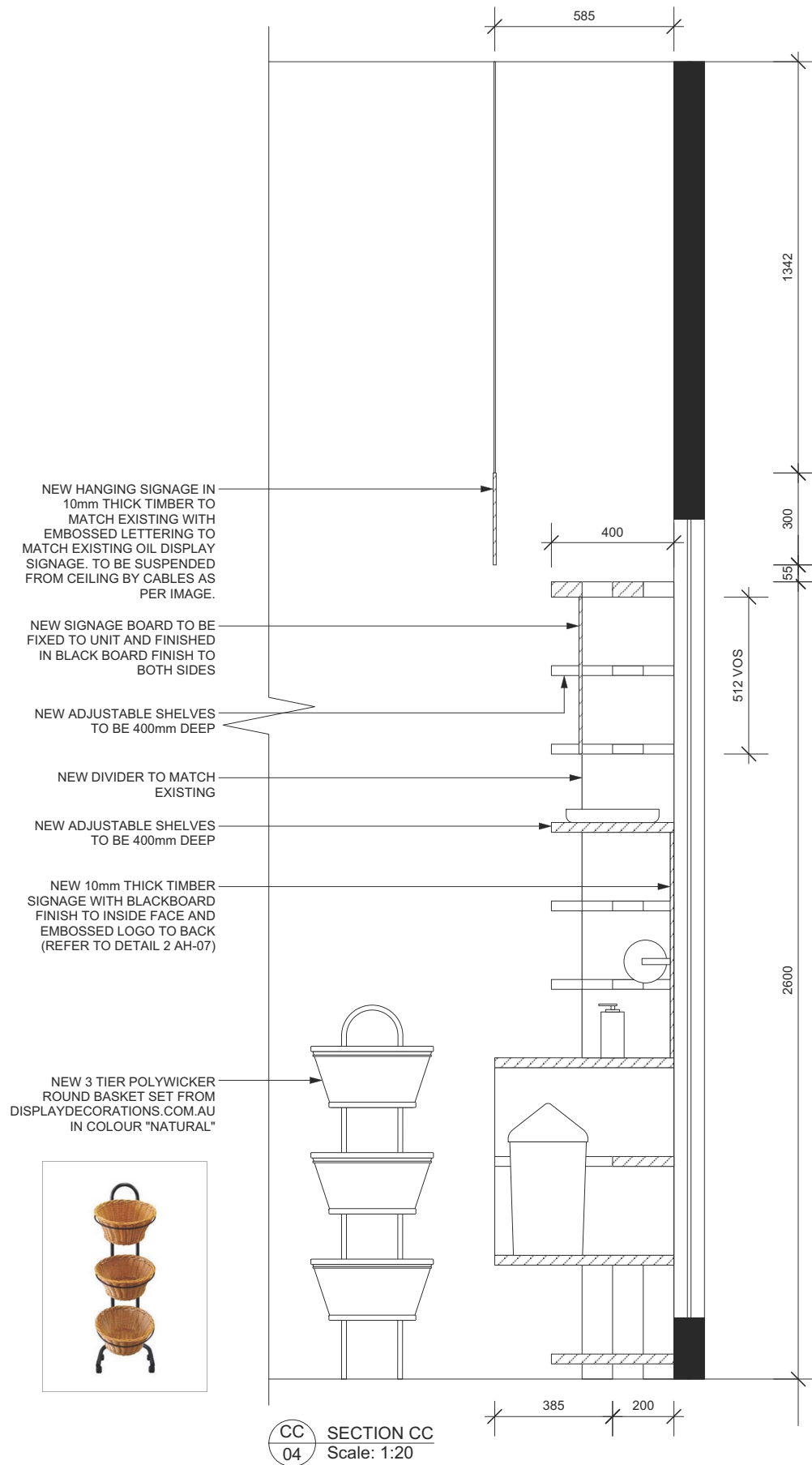

NOTES:

SHOPFITTER TO VOS ALL DIMENSIONS ON SITE PRIOR TO ORDERING AND/OR COMMENCING MANUFACTURE.

SHOPFITTER TO ENSURE ALL WORKS COMPLY WITH FOOD CODE, NCC, AUSTRALIAN STANDARDS AND COUNCIL REGULATIONS.

FD forward thinking design.
 ABN: 27 141 981 179
 8/ Suite 201, Lakeside Corporate Centre,
 29-31 Solent Circuit, Baulkham Hills, 2153
 Mobile Ph: 0403 867 807
 Ph: 02 8850 4977
 Email: vanessa@forwardthinkingdesign.com.au

NOTES:
 All dimensions are in mm. Do not scale off drawing.
 Contractors to verify all dimensions on site & inspect site conditions prior to commencement of construction.
Contractors to ensure all works comply with NCC, Australian Standards and Council regulations.

Contractors to ensure strength & stability of units & also that no deflection occurs.

Any variations to specifications &/or drawings must be authorised by Forward Thinking Design prior to construction. Do not substitute finishes or light fittings specified unless authorised by Forward Thinking Design.

© Copyright of Forward Thinking Design.

REV.	DATE	AMENDMENT	BY
A	02/06/17	SINK TO REMAIN, NEW SHELF FOR GRINDER, HOME ITEMS/DRY GOOD SHELF MOVED, FREEZER SIZE CHANGED, LOW HEIGHT UNITS SIZE ADJUSTED	EH

PROJECT:
 ALFALFA HOUSE
 113 ENMORE RD, ENMORE, NSW 2042

DRAWING TITLE:
 SECTION CC

FOR APPROVAL		DRAWN
SCALE 1:20	DATE 06/07/17	CHECKED VC
DRG NO. AH-05	REVISION	APPROVED

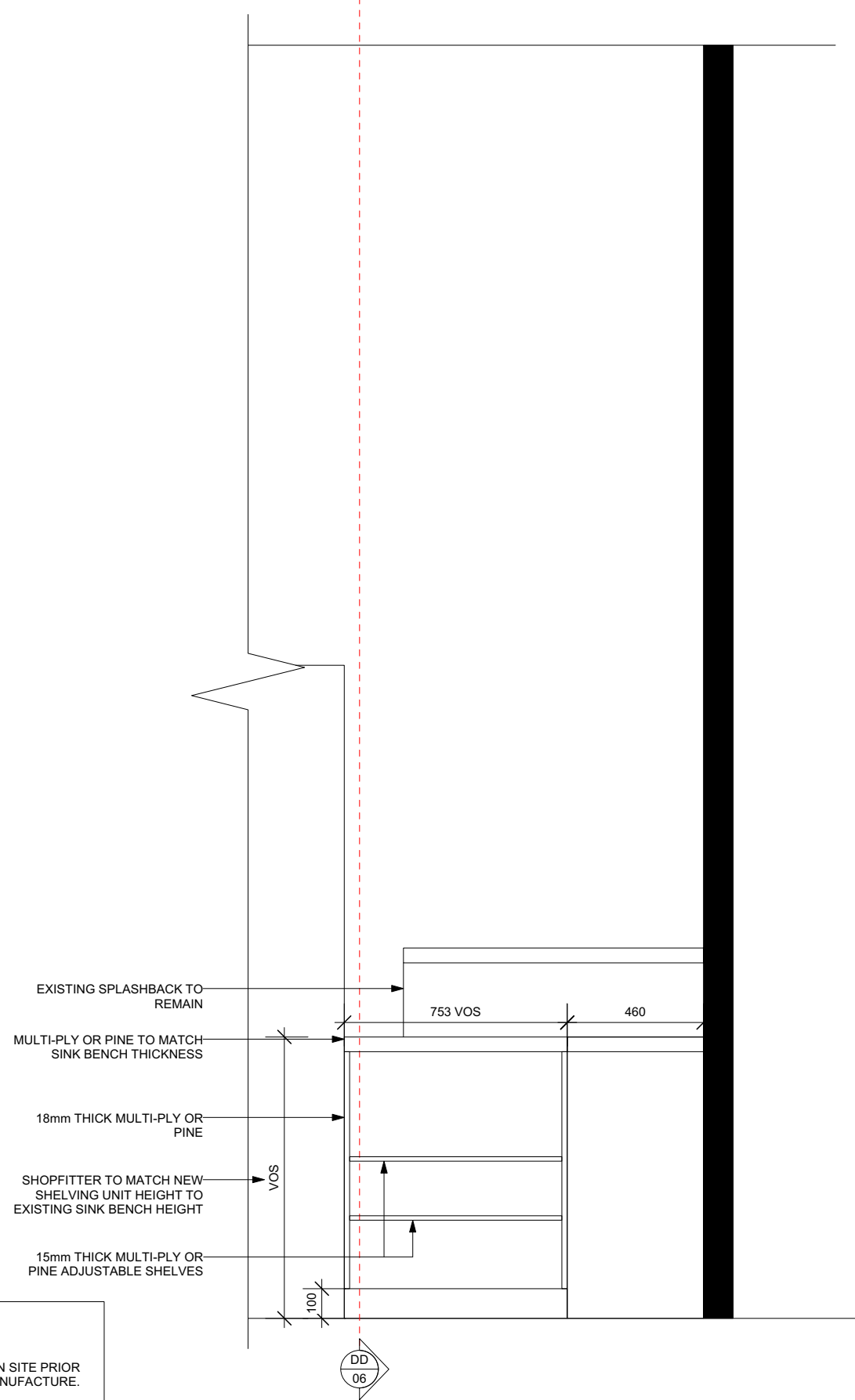

D
02 ELEVATION D
Scale: 1:20

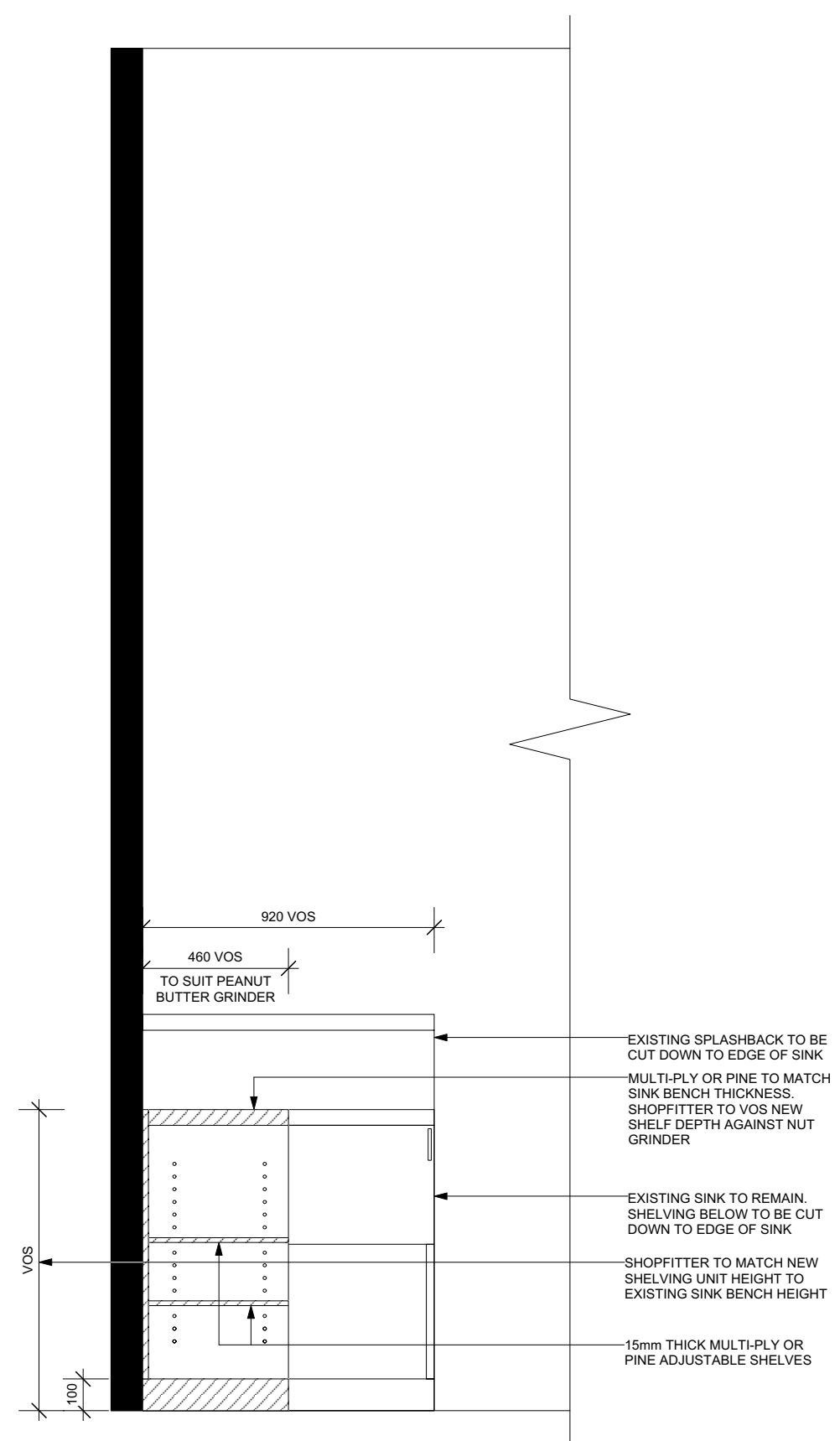

D
06 SECTION DD
Scale: 1:20

NOTES:
SHOPFITTER TO VOS ALL DIMENSIONS ON SITE PRIOR TO ORDERING AND/OR COMMENCING MANUFACTURE.

SHOPFITTER TO ENSURE ALL WORKS COMPLY WITH FOOD CODE, NCC, AUSTRALIAN STANDARDS AND COUNCIL REGULATIONS.

FD forward thinking design
A&B: 27 141 981 179
8/ Suite 201, Lakeside Corporate Centre,
29-31 Solent Circuit, Baulkham Hills, 2153
Mobile Ph: 0403 867 807
Ph: 02 8850 4977
Email: vanessa@forwardthinkingdesign.com.au

NOTES:
All dimensions are in mm. Do not scale off drawing. Contractors to verify all dimensions on site & inspect site conditions prior to commencement of construction.
Contractors to ensure all works comply with NCC, Australian Standards and Council regulations.

Contractors to ensure strength & stability of units & also that no deflection occurs.

Any variations to specifications &/or drawings must be authorised by Forward Thinking Design prior to construction. Do not substitute finishes or light fittings specified unless authorised by Forward Thinking Design.

© Copyright of Forward Thinking Design.

REV.	DATE	AMENDMENT	BY
A	02/06/17	SINK TO REMAIN, NEW SHELF FOR GRINDER, HOME ITEMS/DRY GOOD SHELF MOVED, FREEZER SIZE CHANGED, LOW HEIGHT UNITS SIZE ADJUSTED	EH

PROJECT:
ALFALFA HOUSE
113 ENMORE RD, ENMORE, NSW 2042

DRAWING TITLE:
ELEVATION D

FOR APPROVAL		DRAWN
SCALE 1:20	DATE 06/07/17	EH
DRG NO. AH-06	REVISION	VC
		APPROVED

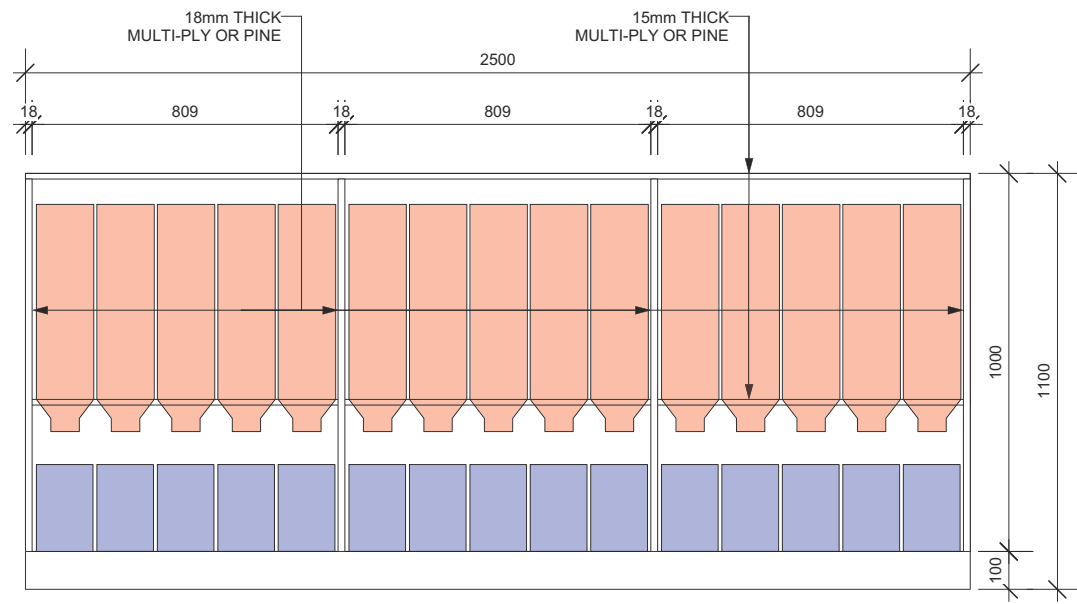

A ELEVATION A
09 Scale: 1:20

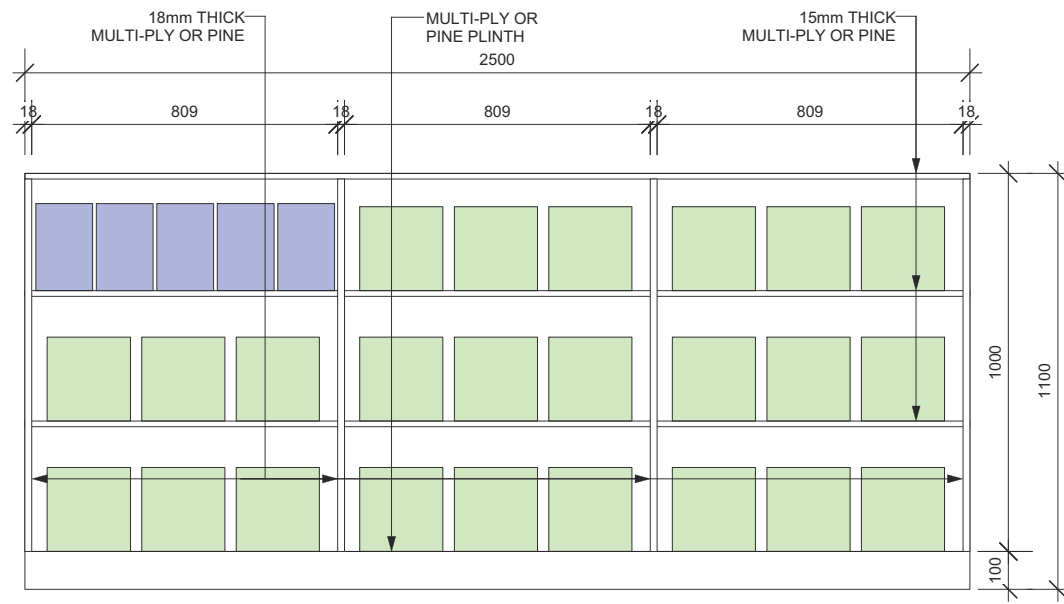

B ELEVATION B
09 Scale: 1:20

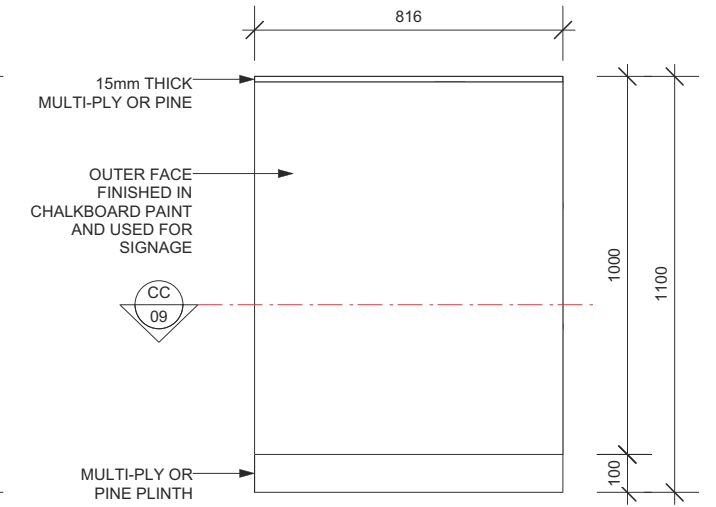

C ELEVATION C
09 Scale: 1:20



FLOOR UNIT 2 - PLAN
09 Scale: 1:20

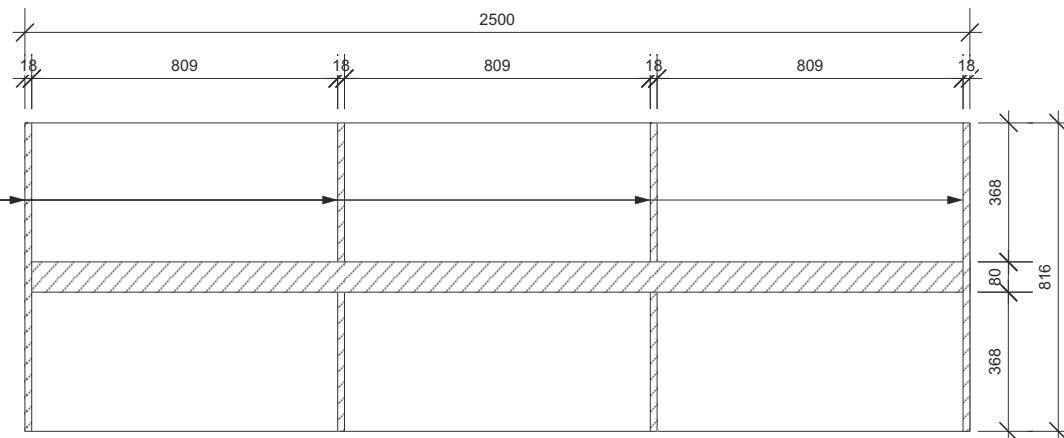

CC SECTION CC
09 Scale: 1:20

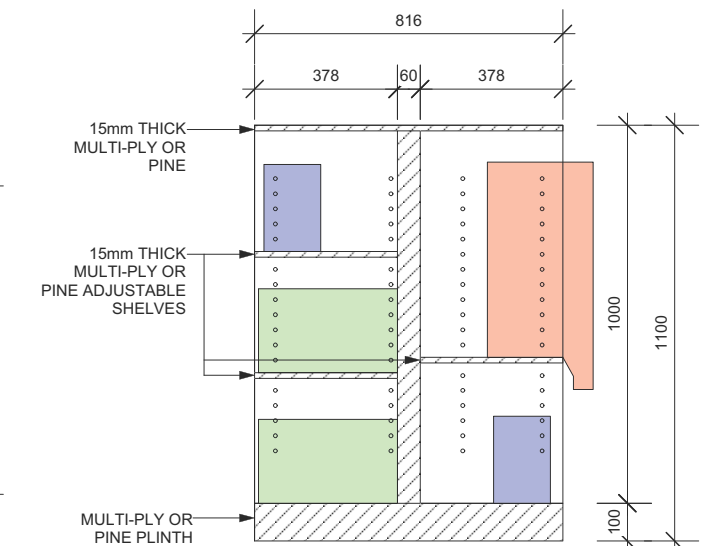

DD SECTION DD
09 Scale: 1:20

NOTES:

SHOPFITTER TO VOS ALL DIMENSIONS ON SITE PRIOR TO ORDERING AND/OR COMMENCING MANUFACTURE.

SHOPFITTER TO ENSURE ALL WORKS COMPLY WITH FOOD CODE, NCC, AUSTRALIAN STANDARDS AND COUNCIL REGULATIONS.

NOTE:

MANUFACTURER TO VERIFY SHELF DEPTH AND WIDTH AGAINST CONTAINERS

MANUFACTURERS TO ENSURE ADEQUATE SHELF THICKNESS AND SUPPORTS TO PREVENT SAGGING/WARPING WHEN SHELVES UNDER FULL LOAD.

ALL TIMBER TO BE CLEAR SEALED AGAINST MOISTURE

LEGEND

- GRAVITY FEED DISPENSERS
- STANDARD CONTAINERS
- SCOOP BINS

FD forward thinking design.
A/N: 27 141 981 179
8/ Suite 201, Lakeside Corporate Centre,
29-31 Solent Circuit, Baulkham Hills, 2153
Mobile Ph: 0403 867 807
Ph: 02 8850 4977
Email: vanessa@forwardthinkingdesign.com.au

NOTES:
All dimensions are in mm. Do not scale off drawing.
Contractors to verify all dimensions on site & inspect site conditions prior to commencement of construction.
Contractors to ensure all works comply with NCC, Australian Standards and Council regulations.

Contractors to ensure strength & stability of units & also that no deflection occurs.
Any variations to specifications &/or drawings must be authorised by Forward Thinking Design prior to construction. Do not substitute finishes or light fittings specified unless authorised by Forward Thinking Design.
© Copyright of Forward Thinking Design.

REV.	DATE	AMENDMENT	BY
A	02/06/17	SINK TO REMAIN, NEW SHELF FOR GRINDER, HOME ITEMS/DRY GOOD SHELF MOVED, FREEZER SIZE CHANGED, LOW HEIGHT UNITS SIZE ADJUSTED	EH

PROJECT: ALFALFA HOUSE 113 ENMORE RD, ENMORE, NSW 2042
DRAWING TITLE: FLOOR UNIT 2

FOR APPROVAL		DRAWN
SCALE 1:20	DATE 06/07/17	EH
DRG NO. AH-09	REVISION	VC
		APPROVED

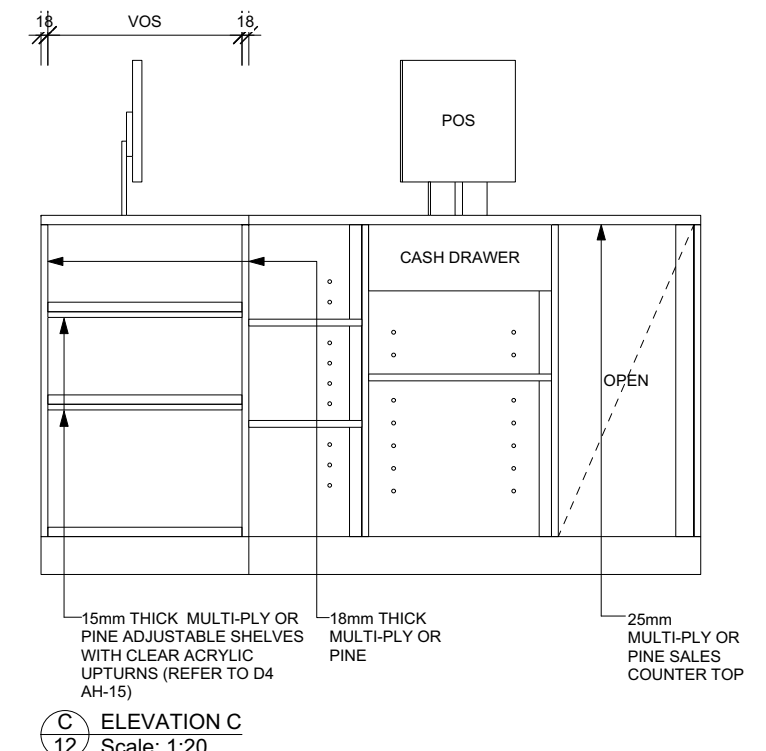
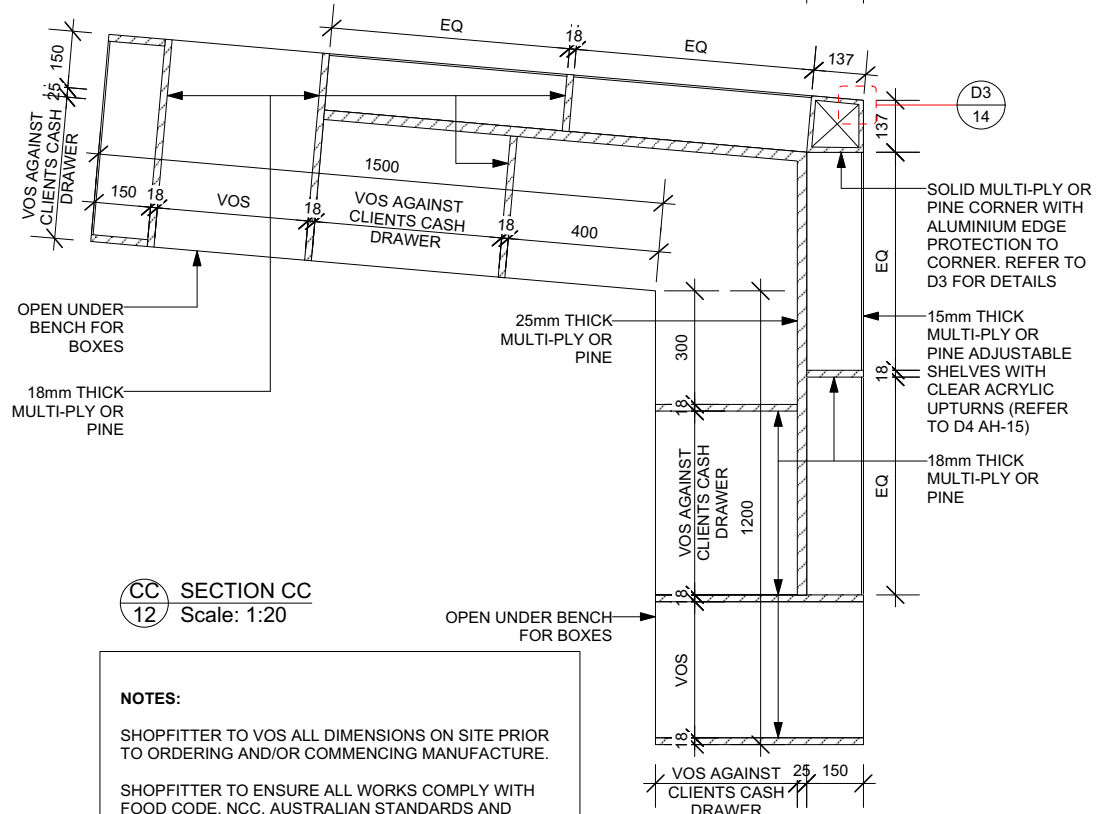
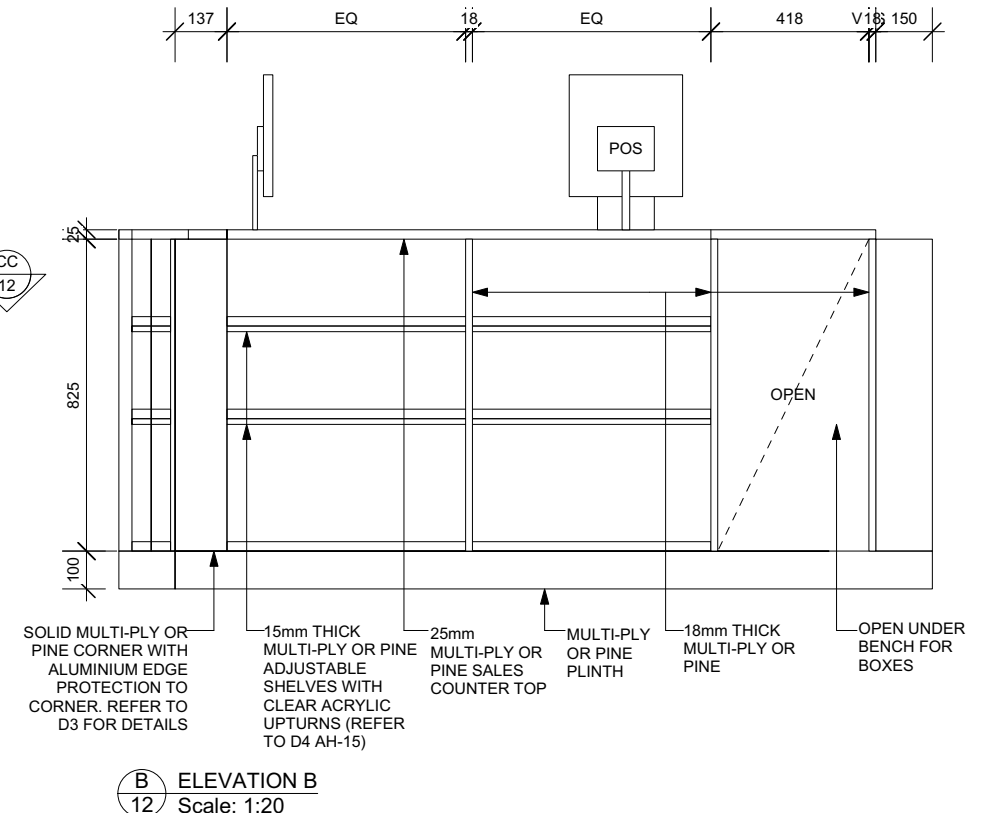
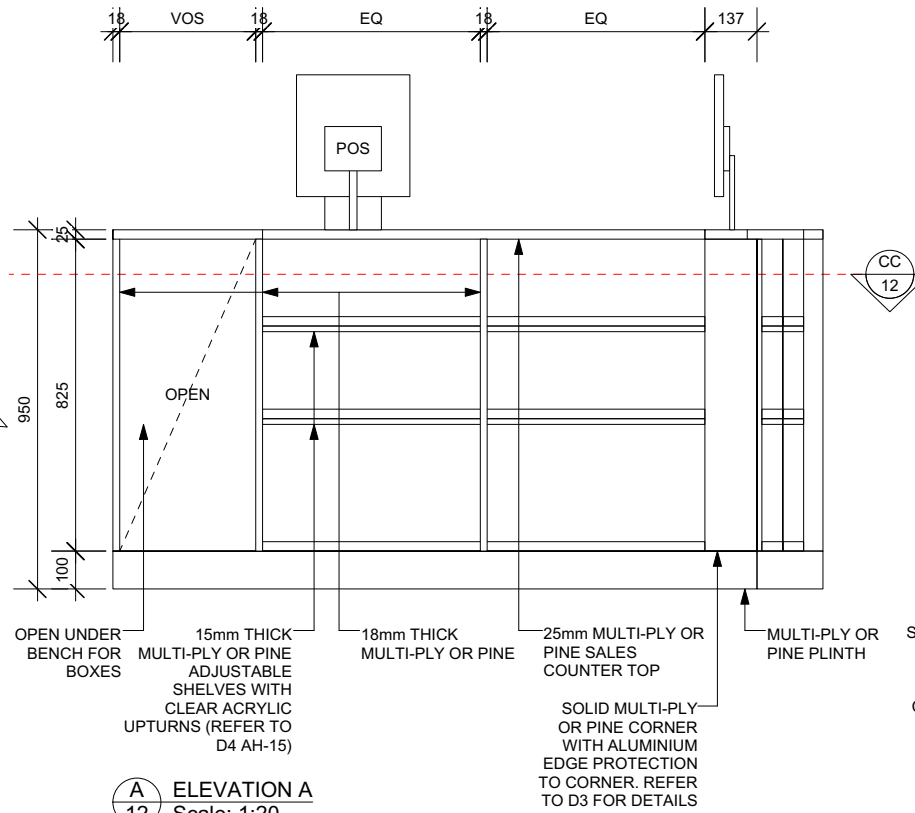
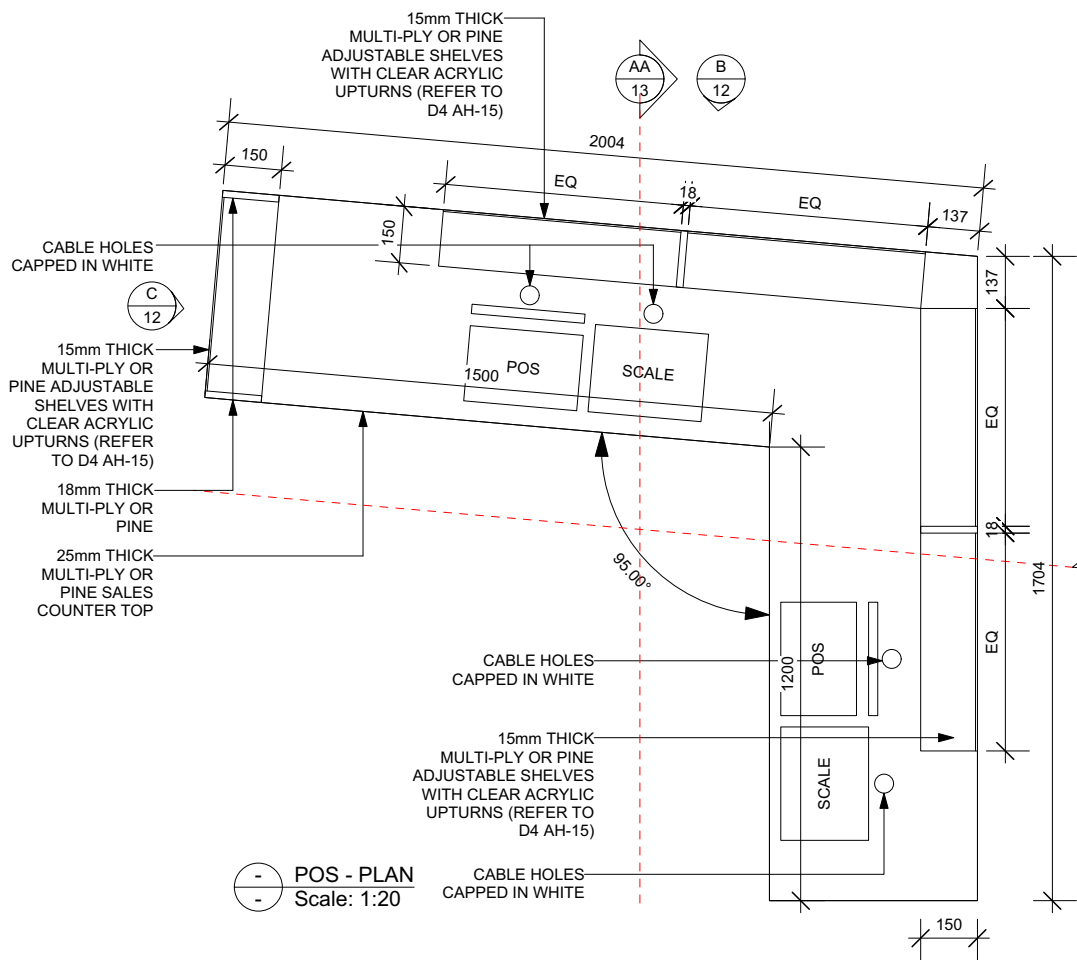

NOTES:

SHOPFITTER TO VOS ALL DIMENSIONS ON SITE PRIOR TO ORDERING AND/OR COMMENCING MANUFACTURE.

SHOPFITTER TO ENSURE ALL WORKS COMPLY WITH FOOD CODE, NCC, AUSTRALIAN STANDARDS AND COUNCIL REGULATIONS.

FD forward thinking design.

ABN: 27 141 981 179
8/ Suite 201, Lakeside Corporate Centre,
29-31 Solent Circuit, Baulkham Hills, 2153
Mobile Ph: 0403 867 807
Ph: 02 8850 4977
Email: vanessa@forwardthinkingdesign.com.au

NOTES:

All dimensions are in mm. Do not scale off drawing. Contractors to verify all dimensions on site & inspect site conditions prior to commencement of construction.

Contractors to ensure all works comply with NCC, Australian Standards and Council regulations.

Contractors to ensure strength & stability of units & also that no deflection occurs.

Any variations to specifications &/or drawings must be authorised by Forward Thinking Design prior to construction. Do not substitute finishes or light fittings specified unless authorised by Forward Thinking Design.

© Copyright of Forward Thinking Design.

REV.	DATE	AMENDMENT	BY
A	02/06/17	SINK TO REMAIN, NEW SHELF FOR GRINDER, HOME ITEMS/DRY GOOD SHELF MOVED, FREEZER SIZE CHANGED, LOW HEIGHT UNITS SIZE ADJUSTED	EH

PROJECT:
ALFALFA HOUSE
113 ENMORE RD, ENMORE, NSW 2042

DRAWING TITLE:
POS UNIT 1

FOR APPROVAL		DRAWN
SCALE 1:20	DATE 06/07/17	EH
DRG NO. AH-12	REVISION	CHECKED VC
		APPROVED

Quote

Oliver Fity
0426875234
oliverfity@gmail.com

17/07/17

ABN 25 800 422 157

Description of work	
- Build and Install floor units	1 \$3238.2
	2 \$3434.2
	3 \$3418.3
	4 \$3418.3
- Build and Install POS	\$4286
- Make internal ply signage and install (no paint)	\$3000
- Remove bench next to sink (enmore rd side)	\$150
- Remove bench next to sink (phillip st side) and build new cupboard/shelf with stainless top	\$500
- Modify tall narrow shelving and move into new position	\$300
- Remove old dispenser units	\$150
- Modify front window shelving to be 400mm deep and add extra dividers	\$420
- Move fridges	\$150
- Scaffold hire	\$430

Quote Excludes
<ul style="list-style-type: none">- New 1 door freezer- Bin, Paper towel holder, soap etc- Vinyl graphics- Electrical work- Pos computer systems- 3 tier poly wicker- Painting signage

TOTAL: \$22895

Note: This is a quote based on current drawing at the time and is not a contract or bill. It is my best estimate at the total price to complete the work stated above based on my initial inspection. If changes are made and additional work is required, I will inform you prior to proceeding.

20th July 2017
Alfalafa House
113 Enmore Rd
Enmore NSW
2042

Fit-out **Crew**
QUOTATION (CREW/Alfalafa)

Attention: Maurice

Re: Budget quotation Forward Thinking Design

Dear Maurice,

We are please to submit our **budget quotation** to the above-mentioned location for the manufacture, supply and installation of the following work :-

1. Joinery

- Floor units 1,2,3,4
- Service counter
- Nut grinder shelf
- Relocate Tall narrow (dry goods/home goods) **\$ 20,000.00**

2. SIGNAGE

- Suspended signs
- Window graphics
- Chalk boards **\$ 7,000.00**

3. FLOORING

- Vinyl to floor as indicated **\$ 1,000.00**

4. PRELIMINARIES & CERTIFICATION

- Site meetings
- Site management
- OHS&E
- On site labour supervision & co ordination
- Delivery of the above items to site **\$ 12,000.00**

QUOTATION (CREW/Alfa)

QUOTATION (CREW/STAUN1A)

OUR ESTIMATED BUDGET FOR THIS WORK BEING : \$40,000.00

We thank you for the opportunity to present our budget quotation and look forward to your consideration and favorable advice

Yours faithfully

Lewis Coutts
0473 238 538

From: Glenda Cathersides Glenda.Cathersides@signaturefloors.com.au 
Subject: RE: Vinyl Flooring
Date: 19 June 2017 at 10:27 AM
To: Manager manager@alfalahouse.org
Cc: adamlamont@patonsflooring.com.au

GC

Hello Maurice,

I have passed on your details to Adam Lamont from Patons Flooring. He will be in contact with you shortly to discuss.

I had been trying to source some Aged stock, that we could offer at a discounted price for you but have not been successful in doing that.

Therefore, the product that we would put forward is the [Signature ITEC Sheet Vinyl](#).

Indicatively, you would be looking at around the mid to high \$60's per m2 supplied and installed excluding any floor prep that may or may not be required and excluding GST.

Adams contact details are M: 0420 990 794 and E: adamlamont@patonsflooring.com.au

I have explained that you require all information by the 22nd to present at a board meeting on the 26th.

Good Luck!

Thanks & Kind Regards
Glenda Cathersides
Corporate Accounts Manager



Signature Floorcoverings Pty Ltd

13 Wurundjeri Drive Epping VIC 3076 Australia
m 0498 210 011 | t 03 9401 0888 | f 03 9401 0866

glenda.cathersides@signaturefloors.com.au

www.signaturefloors.com.au

email is confidential, if you have received this email in error, please notify us by return email and delete this email. If you are the intended recipient, you are hereby notified that any disclosure, copying, disruption or taking any action in reliance on the content of this information is strictly prohibited and maybe unlawful. Signature Floorcoverings Pty Ltd is not liable for the incomplete transmission of the information contained in this communication or for any delay in its receipt.

From: Manager [mailto:manager@alfalahouse.org]

Sent: Friday, 9 June 2017 3:01 PM

To: Glenda Cathersides <Glenda.Cathersides@signaturefloors.com.au>

Subject: Fwd: Vinyl Flooring

Hi Glenda

It was great to speak with you, please find below both design drawings and a photo of the current flooring in our shop.



I look forward to any assistance you can provide.

Regards
Maurice

Maurice Cathersides

maurice Cabrera, manager



ALFALFAHOUSE
COMMUNITY FOOD CO-OP • SINCE 1981
113 Enmore Road Newtown NSW 2042
T 02 9519 3374 W alfalfahouse.org

Begin forwarded message:

From: Designer 4 <designer4@forwardthinkingdesign.com.au>
Subject: Vinyl Flooring
Date: 5 June 2017 at 1:18:03 PM AEST
To: Manager <manager@alfalfahouse.org>
Cc: Vanessa Cullen <vanessa@forwardthinkingdesign.com.au>

Hi Maurice,

Here are the details of our vinyl floor supplier from Signature Floor Coverings:
Glenda Cathersides
p: 0498 210 01
e: glenda.cathersides@signaturefloors.com.au

I've attached a copy of the plan with the sqm required - the area is 7.2sqm but the rep will be able to advise you on how much vinyl is required when wastage is considered.

If you have any questions please let me know!

Kind Regards,

Emma-Jane Henry
Junior Designer



HQ: Office 8, Suite 201, Lakeside Corporate Centre, 29-31 Solent Circuit, Baulkham Hills, NSW 2153
Satellite Office: Office D, Suite 105, Newtown Business Ctr, 1 Erskineville Rd, Newtown NSW 2042

Ph: 02 8850 4977 **Mob:** 0406 341 129
www.forwardthinkingdesign.com.au

Follow us on

Instagram: [forwardthinkingdesign](https://www.instagram.com/forwardthinkingdesign)

Facebook: www.facebook.com/#!/pages/Forward-Thinking-Design/191508704195101

Silver Winner Sydney Design Awards 2016 - *Brown Jersey*
Finalist Hills Building and Design Awards 2016 - *Retail Shop Fitout*
Finalist Western Sydney Awards For Business Excellence 2014
TEC - *Vanessa Cullen - CEO of the Year 2013*
Finalist Hills Building and Design Awards 2013 - *Retail Shop Fitout*
Finalist Sydney Design Awards 2013 - *Pachamama*
Finalist Hills Building Design Awards 2013 - *Cosmo Coffee*

Finalist Hills Branding Design Awards 2013 - *Cosmo Coffee*

Finalist ASOFIA 2012-2013 - *Interior Fitout Awards for Sergio's Cake Shop*

Finalist NSW Business Chambers Business Awards 2012 - *Future Business Leader*

Finalist Retail Design Awards 2012

Winner Western Sydney Awards For Business Excellence 2012 – *Vanessa Cullen - Young Female Entrepreneur of the Year*

Finalist Western Sydney Awards For Business Excellence 2012 – *Excellence in Professional Services & Excellence in Export*

Finalist Telstra Australia Business Awards, HTC Start Up, 2012

Shortlisted in Eat-Drink-Design Awards 2012- *Sergio's Cake Shop Blacktown & Sergio's Cake Shop Marrickville (Best Cafe Design)*

Shortlisted in Sydney Design Awards 2012 - *Sergio's Cake Shop Blacktown*

Quote

Oliver Fity
0426875234
oliverfity@gmail.com

12/08/17

ABN 25 800 422 157

Description of work

Rebuild existing gravity fed sagging shelf
--

TOTAL: \$3300

Note: This is a quote and is not a contract or bill. It is my best estimate at the total price to complete the work stated above based on my initial inspection. If prices change or additional work is required, I will inform you prior to proceeding.

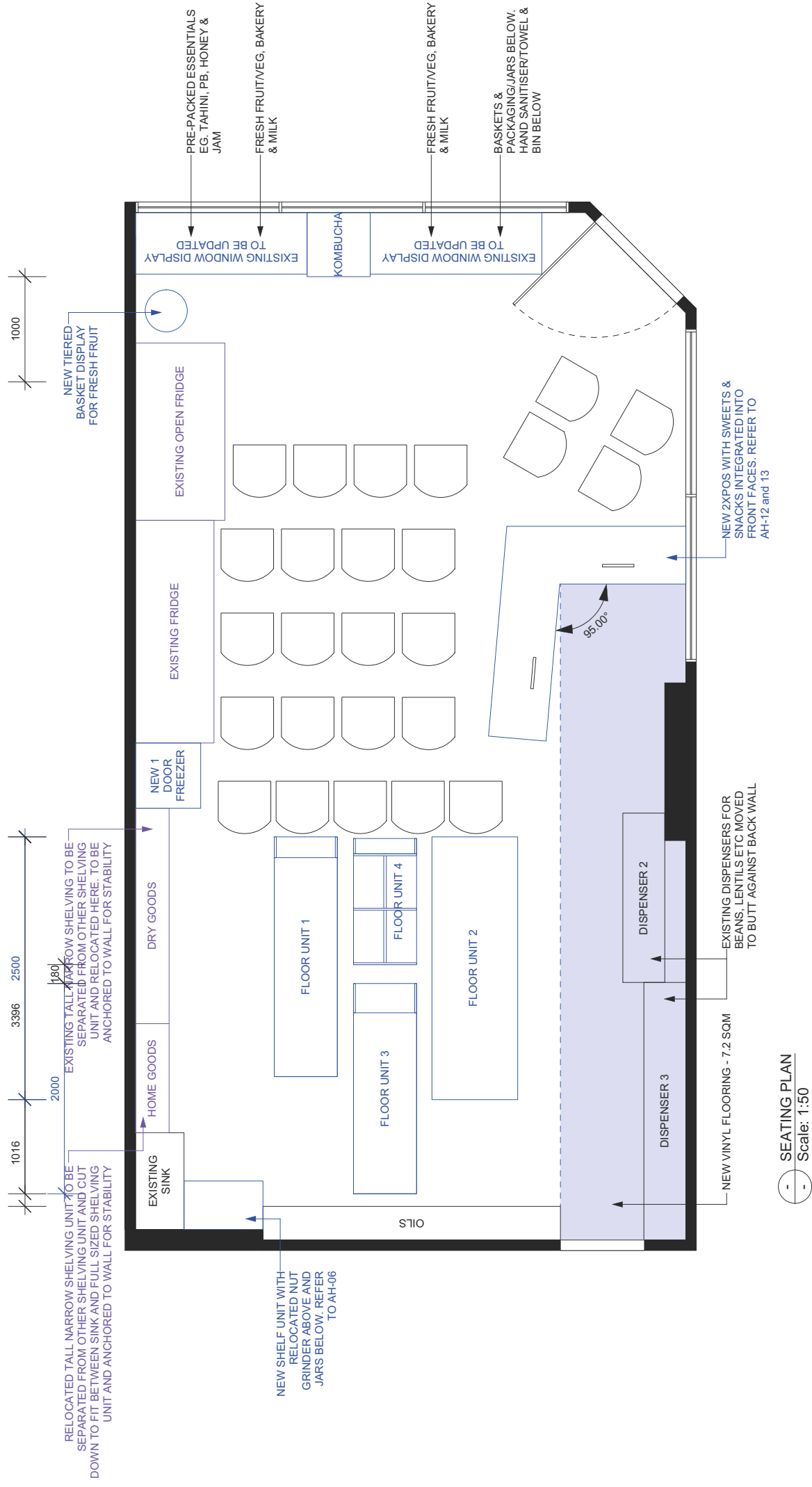

NOTES:
 SHOPFITTER TO VOS ALL DIMENSIONS ON SITE PRIOR TO ORDERING AND/OR COMMENCING MANUFACTURE.
 SHOPFITTER TO ENSURE ALL WORKS COMPLY WITH FOOD CODE, NCC, AUSTRALIAN STANDARDS AND COUNCIL REGULATIONS.

forward thinking design
FD
 ABN: 27 141 981 179
 8/ Suite 201, Lakeside Corporate Centre,
 29-31 Solent Circuit, Baukham Hills, 2153
 Mobile Ph: 0403 867 807
 Ph: 02 8850 4977
 Email: vanessa@forwardthinkingdesign.com.au

NOTES:
 All dimensions are in mm. Do not scale off drawing. Contractors to verify all dimensions on site & inspect site conditions prior to commencement of construction.
Contractors to ensure all works comply with NCC, Australian Standards and Council regulations.

Contractors to ensure strength & stability of units & also that no deflection occurs.
 Any variations to specifications &/or drawings must be authorised by Forward Thinking Design prior to construction. Do not substitute finishes or light fittings specified unless authorised by Forward Thinking Design.
 © Copyright of Forward Thinking Design.

REV.	DATE	AMENDMENT
A	02/06/17	SINK TO REMAIN, NEW SHELF FOR GRINDER, HOME ITEMS/DRY GOOD SHELF MOVED, FREEZER SIZE CHANGED, LOW HEIGHT UNITS SIZE ADJUSTED

BY: EH
 PROJECT: ALFALFA HOUSE
 113 ENMORE RD, ENMORE, NSW 2042
 DRAWING TITLE: SEATING PLAN

FOR APPROVAL		SCALE	DATE	DRWN
1:50	07/08/17	EH	CHECKED	EH
DRG NO. AH-02A	REVISION	VC	APPROVED	VC

Product	Qty.	Price per unit	Reg. Price	Mem. Price	Vol. Price	Potential Sales	Cost of sales	Profit	Notes
New products									
Funky Pies	48	\$3.58	\$6.27	\$5.64	\$4.70	\$270.65	\$171.84	\$99	Bulk purchase 12 pies in a box
Funky Pies (Gluten Free)	48	\$4.20	\$7.35	\$6.62	\$5.51	\$317.52	\$201.60	\$116	Bulk purchase 12 pies in a box
Vege Stock		\$0.00	\$0.00	\$0.00	\$0.00				Searching for product in glass packaging
Over the moo (coconut ice-cream)	500ml	\$6.66	\$11.66	\$10.49	\$8.74	\$315	\$200	\$115	Cardboard packaging
Knox & Aya (coconut ice-cream)	500ml	\$10.66	\$18.66	\$16.79	\$13.99	\$504	\$320	\$184	Cardboard packaging
Mixed berries (organic)	10kg	\$115.50	\$202.13	\$181.91	\$151.59	\$364	\$231	\$133	Based on current trend of sales of strawberries and bluberry punnets
Previously Discontinued Products									
Byron Bay Tempeh (organic)	ea	\$6.65	\$11.64	\$10.47	\$8.73	\$367	\$233	\$134	avg 35/mth = \$366.50
White Mulberries (organic)	1kg	\$15.20	\$26.60	\$23.94	\$19.95	\$48	\$30	\$17	previously sold 2kg/month = \$47.88 (at member price)
New Fridge products									
Comboyne Cheese (co-operative)	ea	\$8.30	\$14.53	\$13.07	\$10.89	\$392	\$249	\$143	
Bulk Pesto	2L	\$40.00	\$70.00	\$63.00	\$52.50	\$50	\$32	\$19	avg 1.6kg/mth
Bulk Tortillas	1kg	\$10.00	\$17.50	\$15.75	\$13.13	\$32	\$20	\$12	
Total:						\$2,659	\$1,688	\$971	

Including a single door commercial freezer in the shop would allow us to:

- diversify range through introduction of new products (such as coconut ice cream and mixed berries)
- return previously discontinued products (such as Byron Bay Tempeh and white mulberries)
- reduce waste by storing current products only available in large quantities (such as arlingtons dips, spring wholefoods breads and raw love balls)
- create space in fridge for new products (such as Comboyne soft cheeses, bulk tortillas and bulk pesto) made by moving existing items (such as tempeh) to freezer.

Running costs of a 400L single door commercial fridge are very difficult to determine without the exact model specifications, however potential profit has been calculated as follows:

- member pricing
- existing or previously stocked products based on average monthly sales
- new products based on sale of 1 item or 100g per day over a one month period (except for tortillas, which have been estimated as selling 2/mth)
- profit based on 75% margin

Running costs approx \$120 per year based on 4-star rating and 430L (<http://www.environment.nsw.gov.au/households/fridges-freezers.htm>)

Purchase price \$3,415 for Sanden single glass door display freezer 409L

Based on the above products the inclusion of a freezer on the shop area would increase revenue by \$2,659 per month with a potential profit of \$11,652 per year. It is likely that this figure would be higher as more products would be introduced to the fridge and freezer than those listed above. Payback period would be 3.5months.

SANDEN INTERNATIONAL PRICE LIST – Jan 2017

GLASS DOOR DISPLAY FREEZER



- Rated to operate at 32°C and 65% humidity
- Semi removable refrigeration unit for ease of service
- Self-closing lockable doors
- LED Lighting provides premium product illumination
- Magnetic removable door gaskets
- DIXELL electronic controller for energy saving and accurate control
- Triple pane heated Low-E glass
- Anti-corrosive coil coating
- Cyclo-Pentane blown polyurethane foam 100% CFC free insulation
- 6 plastic coated steel shelves
- LED Lightbox
- Powder coated galvanised steel for durability
- Full Australian Safety, MEPS and RCM Certifications and Approvals
- 2 YEAR PARTS AND LABOUR WARRANTY

ARRIVING MARCH 2017

SINGLE DOOR DISPLAY FREEZER – GLASS DOOR- 409 LITRE

MODEL	DESCRIPTION	DIMENSIONS H x W x D mm	OPERATING TEMP.	RRP AU\$ + GST
SNR-0503W	SINGLE GLASS DOOR DISPLAY FREEZER - WHITE	1966H X 670W X 710D	-18°C to -25°C @ 32°C/65%	\$3,415

All prices plus GST

